

Sanitary Diaphragm Valve

Pneumatically actuated

Description

The type 625 is an extremely compact pneumatically actuated valve with many features which make them ideal for pharmaceutical and bio-processing applications.

Standard Features

- Extremely compact design
- Sanitary internals
- Visual position indicator
- Maintenance-free piston actuator: Normally Open, Normally Closed or Double Acting
- FDA compliant diaphragms
- Body material 316L stainless steel
- Triclamp®, O.D. Tubing, ISO, and DIN end connections
- Sizes 3/8" - 3/4"

Available Options

- Electrical limit and proximity switches
- Stroke limiter
- Pneumatic and electro-pneumatic positioners

Special connections

Hose barb, tube extensions, Swagelok®, Cajon VCR®, Ingold®, and others available upon request.

Fabrications

Cluster valve assemblies for horizontal and vertical orientations, Bottle Sampling, and custom fabrications upon request.

Materials

AL-6XN®, Hastelloy®, Titanium, and others available upon request.

Typical Applications

- Pharmaceutical manufacturing
- Bioprocessing
- Cosmetic
- Brewery Service
- Food and Beverage
- Semiconductor
- High Purity Chemicals



Type 625 Technical Data

Size (In.)	Nominal diameter (mm)	Body configuration D = straight through	Working pressure (psi)	Control pressure (psi) Control function		C _v -value (gpm)		Weight (lbs)
				1	2 + 3	ISO Connection	O.D. Tubing	
3/8"	10	D	0 - 90	max. 105	max. 75	5.62	3.51	.99
-	12	D	0 - 90	max. 105	max. 75	-	-	1.1
1/2"	15	D	0 - 90	max. 105	max. 75	7.02	4.10	1.5
3/4"	20	D	0 - 90	max. 105	max. 75	-	5.60	1.5

Flow Medium
Max. Permissible temperature of working medium: 302° F
(Depending on diaphragm material)

Control medium
Max. Perm. Temperature of the pilot medium: 104°F
Filling volume: 1.8 cu. in.

All pressures are gauge pressures when applied upstream only

Body Configuration

Tank bottom valve body
2-way valve body
2-way angled valve body
Multiported valve body
Zero Static T-Valve
U-bend

Ref.no.

B
D
E
M
T
U

Connection

DIN
DIN 11850/Series 1
DIN 11850/Series 2
DIN 11850/Series 3
Butt weld OD tubing
Sizes 1/4-3/8" 20 gauge .035" wall
Sizes 1/2-3" 16 gauge .065" wall
Sizes 4" 14 gauge .083" wall
ISO
Schedule 10 pipe
Tri-clamp®
O.D. Tubing by Triclamp®
Extended O.D. Tubing
Extended O.D. Tubing by Triclamp®

Ref.no.

0
16
17
18
59
60
63
80
93
94
95

Body material

Investment cast body

Stainless steel 316 L \triangleq 1.4435 (BN2) Fe < 0.5%
Stainless steel 1.4539 (UNS N 08904)

Ref.no.

32
33
34

Forged Body

Stainless steel 316 L \triangleq 1.4435 (ASTM A 182)
Stainless steel 316 L \triangleq 1.4435 (BN2) Fe < 0.5%

40
42

Machined block

Stainless steel 316 L \triangleq 1.4435 (ASTMA 182)

41

Special versions

(Consult factory for special material reference numbers)

91

Required Control Pressure

	Normally Closed (1)	Normally open + air to air (2+3)
Min.	60 psi	60 psi
Max.	105 psi	75 psi

Diaphragm material

		Ref.no.
Ethylene-propylene Rubber for saturated steam max 302° F	EPDM	13
Ethylene-propylene Rubber for saturated steam max 302° F	EPDM	16
2nd generation, modified Teflon® with Ethylene-propylene backing (two-piece)	TFM/EPDM	50
2nd generation, modified Teflon® with Ethylene-propylene backing	TFM/EPDM	52

All diaphragms listed conform to the FDA code of Federal Regulations paragraph 177.2600 of section 21.

Control function

Normally closed
Normally open
Double acting

Ref.no.

1
2
3

Surface finish

μ -in.	BPE Surface Designation	Ra Average [Note (1)]		Ra Max		Ref.no.	
		μ -in.	μ m	μ -in.	μ m		
32	Mechanical					3	
25	Mechanical	SFV3	25	0.625	30	0.750	1502
20	E-pol	SFV6	20	0.500	25	0.625	1508
20	Mechanical	SFV2	20	0.500	25	0.625	1507
15	E-pol	SFV5	15	0.375	20	0.500	1537
11	Mechanical	SFV1	15	0.375	20	0.500	1536
10	E-pol	SFV4	10	0.250	15	0.375	1516

GENERAL NOTE: All Ra readings are taken across the grain.

NOTE: (1) The average Ra is derived from two readings taken at different locations.

Special Versions

Special versions

Ref.no.

UXXXX

Order Example	-625	015	U	80	40	13	1			040	94	1537		
Type of valve	-625													
Size DN		015												
Body configuration			U											
Connection (valve body)				80										
Body material					40									
Diaphragm material						13								
Control function							1							
Actuator size														
Locking device														
Pipe main size										040				
Pipe main connection											94			
Surface finish												1537		
Special versions (XXXX)														

Type 625 Dimensional Data

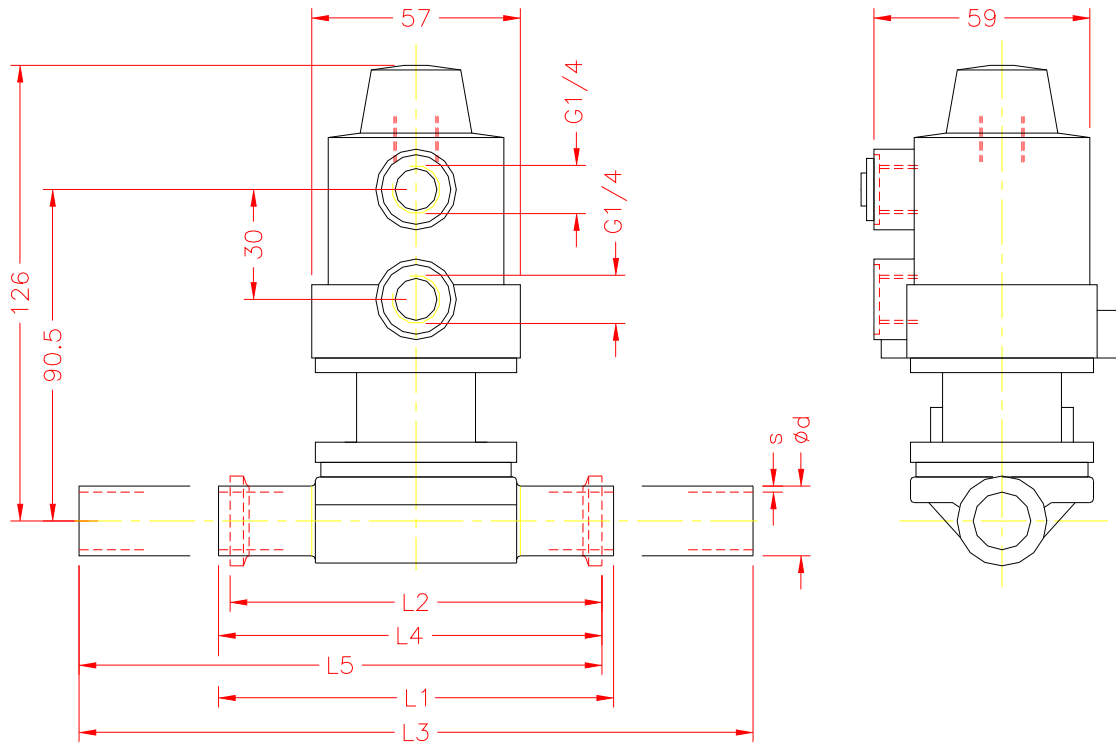

Take Out Dimension For Standard Connections

Size	DN	Units	Con. Ref. No.		(59)	(80)	(94)	(93)	(95)
			Ød	s	L1	L2	L3	L4	L5
3/8	10	mm	9.53	1.25	108.00	88.90	184.20	98.45	136.55
		in	0.375	0.049	4.252	3.500	7.252	3.876	5.376
1/2	15	mm	12.70	1.65	108.00	88.90	184.20	98.45	136.55
		in	0.500	0.065	4.252	3.500	7.252	3.876	5.376
3/4	20	mm	19.05	1.65	108.00	101.60	184.20	104.80	142.90
		in	0.750	0.065	4.252	4.000	7.252	4.126	5.626

- L1 = Connection Code 59 = Standard butt-weld
- L2 = Connection Code 80 = Standard clamp
- L3 = Connection Code 94 = Standard butt-weld extension (AWF)
- L4 = Connection Code 93 = Standard clamp X butt-weld
- L5 = Connection Code 95 = Standard clamp X butt-weld extension (AWF)

Optional Spigot Dimensions

Connection Reference No.			DIN 0	DIN 11850 Series 1	DIN 11850 Series 2	DIN 11850 Series 3	ISO 60					
Size	DN	L ₁	s	Ød	s	Ød	s	Ød	s	Ød	s	Ød
3/8"	10	108	-	-	1	12	1.5	13	2	14	1.6	17.2
1/2"	15	108	1.5	18	1	18	1.5	19	2	20	1.6	21.3

Drain Angles

Size	DN	Degrees
3/8"	10	60°
1/2"	15	65°
3/4"	20	70°

Drain angles are for BS O.D. Tubing only.

Type 625 Dimensional Data

GEMU® Zero Static T-Valve

Standard Features

- Sterile design
- Mechanical parts isolated from process
- Zero dead-leg with no bacteria entrapment
- Maximum drainage, leaving virtually no residue
- Body machined from 316L stainless steel solid bar stock or specified material
- Compact design
- Minimum tube length of 1.5" for automatic orbital welding

Typical Applications

- WFI point-of-use
- DI systems
- SIP (steam-in-place)
- CIP (clean-in-place)
- Sampling
- Product transfer
- Draining
- Diverting applications of critical process fluids

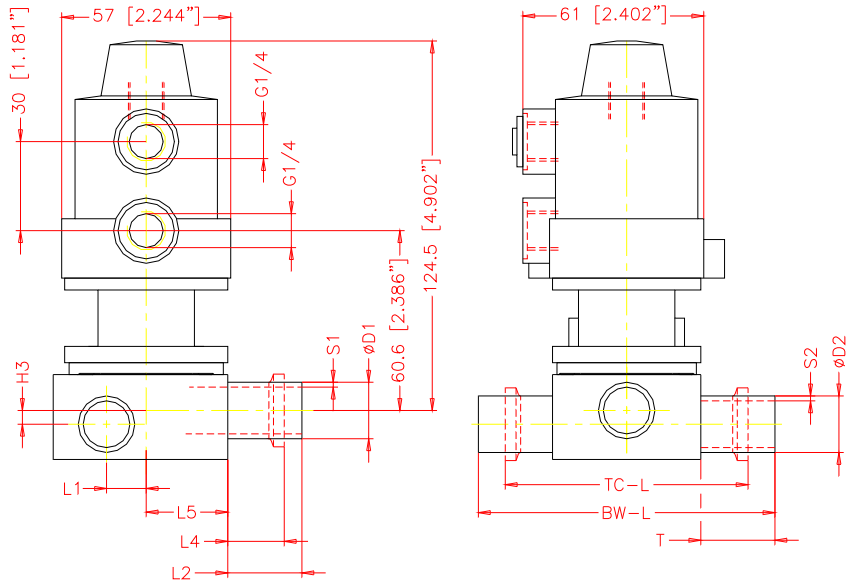

D1 x D2	Units	D1	s1	D2	s2	H3	L1	Code 59			Code 94			Code 80		
								L2	T	BW-L	L2	T	BW-L	L4	L5	TC-L
1/2 x 1/2	mm	12.7	1.65	12.7	1.65	1.45	9.4	20.0	20.0	90.0	38.1	44.9	139.7	19.7	27.5	89.4
	in	0.500	0.065	0.500	0.065	0.1	0.4	0.8	0.8	3.5	1.5	1.8	5.50	0.8	1.1	3.5
1/2 x 3/4	mm	12.7	1.65	19.05	1.65	4.63	12.9	20.0	25.0	100.0	38.1	44.9	139.7	19.7	27.5	89.4
	in	0.500	0.065	0.750	0.065	0.2	0.5	0.8	1.0	3.9	1.5	1.8	5.50	0.8	1.1	3.5
1/2 x 1	mm	12.7	1.65	25.4	1.65	7.8	16.5	20.0	25.0	100.0	38.1	44.9	139.7	19.7	27.5	89.4
	in	0.500	0.065	1.000	0.065	0.3	0.6	0.8	1.0	3.9	1.5	1.8	5.50	0.8	1.1	3.5
1/2 x 1 1/2	mm	12.7	1.65	38.1	1.65	14.15	23.5	20.0	25.0	100.0	38.1	44.9	139.7	19.7	27.5	89.4
	in	0.500	0.065	1.500	0.065	0.6	0.9	0.8	1.0	3.9	1.5	1.8	5.50	0.8	1.1	3.5
1/2 x 2	mm	12.7	1.65	50.8	1.65	20.5	30.6	20.0	30.0	110.0	38.1	44.9	139.7	19.7	27.5	89.4
	in	0.500	0.065	2.000	0.065	0.8	1.2	0.8	1.2	4.3	1.5	1.8	5.50	0.8	1.1	3.5
1/2 x 2 1/2	mm	12.7	1.65	63.5	1.65	26.85	37.6	20.0	30.0	110.0	38.1	44.9	139.7	19.7	27.5	89.4
	in	0.500	0.065	2.500	0.065	1.1	1.5	0.8	1.2	4.3	1.5	1.8	5.50	0.8	1.1	3.5
3/4 x 3/4	mm	19.05	1.65	19.05	1.65	4.63	12.9	25.0	25.0	100.0	38.1	44.9	139.7	19.7	27.5	89.4
	in	0.750	0.065	0.750	0.065	0.2	0.5	1.0	1.0	3.9	1.5	1.8	5.50	0.8	1.1	3.5
3/4 x 1	mm	19.05	1.65	25.4	1.65	7.8	16.5	25.0	25.0	100.0	38.1	44.9	139.7	19.7	27.5	89.4
	in	0.750	0.065	1.000	0.065	0.3	0.6	1.0	1.0	3.9	1.5	1.8	5.50	0.8	1.1	3.5
3/4 x 1 1/2	mm	19.05	1.65	38.1	1.65	14.15	23.5	25.0	25.0	100.0	38.1	44.9	139.7	19.7	27.5	89.4
	in	0.750	0.065	1.500	0.065	0.6	0.9	1.0	1.0	3.9	1.5	1.8	5.50	0.8	1.1	3.5
3/4 x 2	mm	19.05	1.65	50.8	1.65	20.5	30.6	25.0	30.0	110.0	38.1	44.9	139.7	19.7	27.5	89.4
	in	0.750	0.065	2.000	0.065	0.8	1.2	1.0	1.2	4.3	1.5	1.8	5.50	0.8	1.1	3.5
3/4 x 2 1/2	mm	19.05	1.65	63.5	1.65	26.85	37.6	25.0	30.0	110.0	38.1	44.9	139.7	19.7	27.5	89.4
	in	0.750	0.065	2.500	0.065	1.1	1.5	1.0	1.2	4.3	1.5	1.8	5.50	0.8	1.1	3.5

TOL ±1mm Note: Dimension subject to change

Size	1/4	3/8	1/2	3/4	1	1 1/2	2	2 1/2	3	4
DN	8	10	15	20	25	40	50	65	80	100

Order Example	-625	015	T	80	41	13	1		040	94	1537	
Type of valve	-625											
Size DN		015										
Body configuration			T									
Connection (valve body)				80								
Body material					41							
Diaphragm material						13						
Control function							1					
Actuator size												
Locking device												
Pipe main size									040			
Pipe main connection										94		
Surface finish											1537	
Special version (XXXX)												



Type 625 Dimensional Data

GEMU® Zero Static U-Bend Valve

Standard Features

- Sterile design
- Mechanical parts isolated from process
- Zero dead-leg with no bacteria entrapment
- Maximum drainage, leaving virtually no residue
- Body machined from 316L stainless steel solid bar stock or specified material
- Compact design
- Minimum tube length for automatic orbital welding

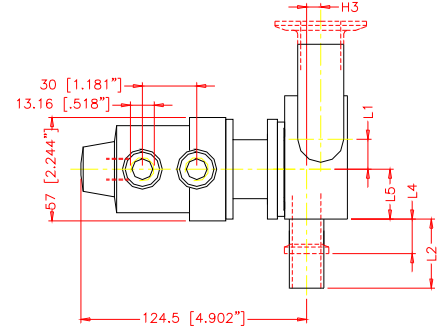
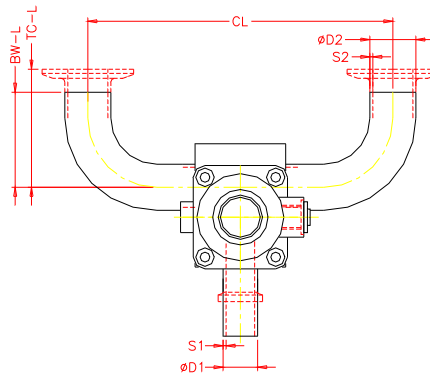

Typical Applications

- WFI point-of-use
- DI systems
- SIP (steam-in-place)
- CIP (clean-in-place)
- Sampling
- Product transfer
- Draining
- Diverting applications of critical process fluids

D1 x D2	Units	D1	s1	D2	s2	H3	L1	Code 59		Code 94		L4	L5	CL	BW-L	TC-L
								L2	L2	L2	L2					
1/2 x 1/2	mm	12.7	1.65	12.7	1.65	1.45	9.4	20.0	38.1	19.7	27.5	216.4	76.2	41.3		
	in	0.500	0.065	0.500	0.065	0.1	0.4	0.8	1.5	0.8	1.1	8.5	3.0	1.6		
1/2 x 3/4	mm	12.7	1.65	19.05	1.65	4.63	12.9	20.0	38.1	19.7	27.5	216.4	76.2	41.3		
	in	0.500	0.065	0.750	0.065	0.2	0.5	0.8	1.5	0.8	1.1	8.5	3.0	1.6		
1/2 x 1	mm	12.7	1.65	25.4	1.65	7.8	16.5	20.0	38.1	19.7	27.5	216.4	76.2	50.8		
	in	0.500	0.065	1.000	0.065	0.3	0.6	0.8	1.5	0.8	1.1	8.5	3.0	2.0		
1/2 x 1 1/2	mm	12.7	1.65	38.1	1.65	14.15	23.5	20.0	38.1	19.7	27.5	254.5	95.3	69.9		
	in	0.500	0.065	1.500	0.065	0.6	0.9	0.8	1.5	0.8	1.1	10.0	3.8	2.8		
1/2 x 2	mm	12.7	1.65	50.8	1.65	20.5	30.6	20.0	38.1	19.7	27.5	305.3	120.7	88.9		
	in	0.500	0.065	2.000	0.065	0.8	1.2	0.8	1.5	0.8	1.1	12.0	4.8	3.5		
1/2 x 2 1/2	mm	12.7	1.65	63.5	1.65	26.85	37.6	20.0	38.1	19.7	27.5	343.4	139.7	108.0		
	in	0.500	0.065	2.500	0.065	1.1	1.5	0.8	1.5	0.8	1.1	13.5	5.5	4.3		
3/4 x 3/4	mm	19.05	1.65	19.05	1.65	4.63	12.9	25.0	38.1	19.7	27.5	216.4	76.2	41.3		
	in	0.750	0.065	0.750	0.065	0.2	0.5	1.0	1.5	0.8	1.1	8.5	3.0	1.6		
3/4 x 1	mm	19.05	1.65	25.4	1.65	7.8	16.5	25.0	38.1	19.7	27.5	216.4	76.2	50.8		
	in	0.750	0.065	1.000	0.065	0.3	0.6	1.0	1.5	0.8	1.1	8.5	3.0	2.0		
3/4 x 1 1/2	mm	19.05	1.65	38.1	1.65	14.15	23.5	25.0	38.1	19.7	27.5	254.5	95.3	69.9		
	in	0.750	0.065	1.500	0.065	0.6	0.9	1.0	1.5	0.8	1.1	10.0	3.8	2.8		
3/4 x 2	mm	19.05	1.65	50.8	1.65	20.5	30.6	25.0	38.1	19.7	27.5	305.3	120.7	88.9		
	in	0.750	0.065	2.000	0.065	0.8	1.2	1.0	1.5	0.8	1.1	12.0	4.8	3.5		
3/4 x 2 1/2	mm	19.05	1.65	63.5	1.65	26.85	37.6	25.0	38.1	19.7	27.5	343.4	139.7	108.0		
	in	0.750	0.065	2.500	0.065	1.1	1.5	1.0	1.5	0.8	1.1	13.5	5.5	4.3		

TOL ±1mm Note: Dimension subject to change

Size	¼	3/8	½	¾	1	1½	2	2½	3	4
DN	8	10	15	20	25	40	50	65	80	100

Order Example	-625	015	U	80	41	13	1		040	94	1537		
Type of valve	-625												
Size DN		015											
Body configuration			U										
Connection (valve body)				80									
Body material					41								
Diaphragm material						13							
Control function							1						
Actuator size													
Locking device													
Pipe main size								040					
Pipe main connection									94				
Surface finish											1537		
Special version (XXXX)													



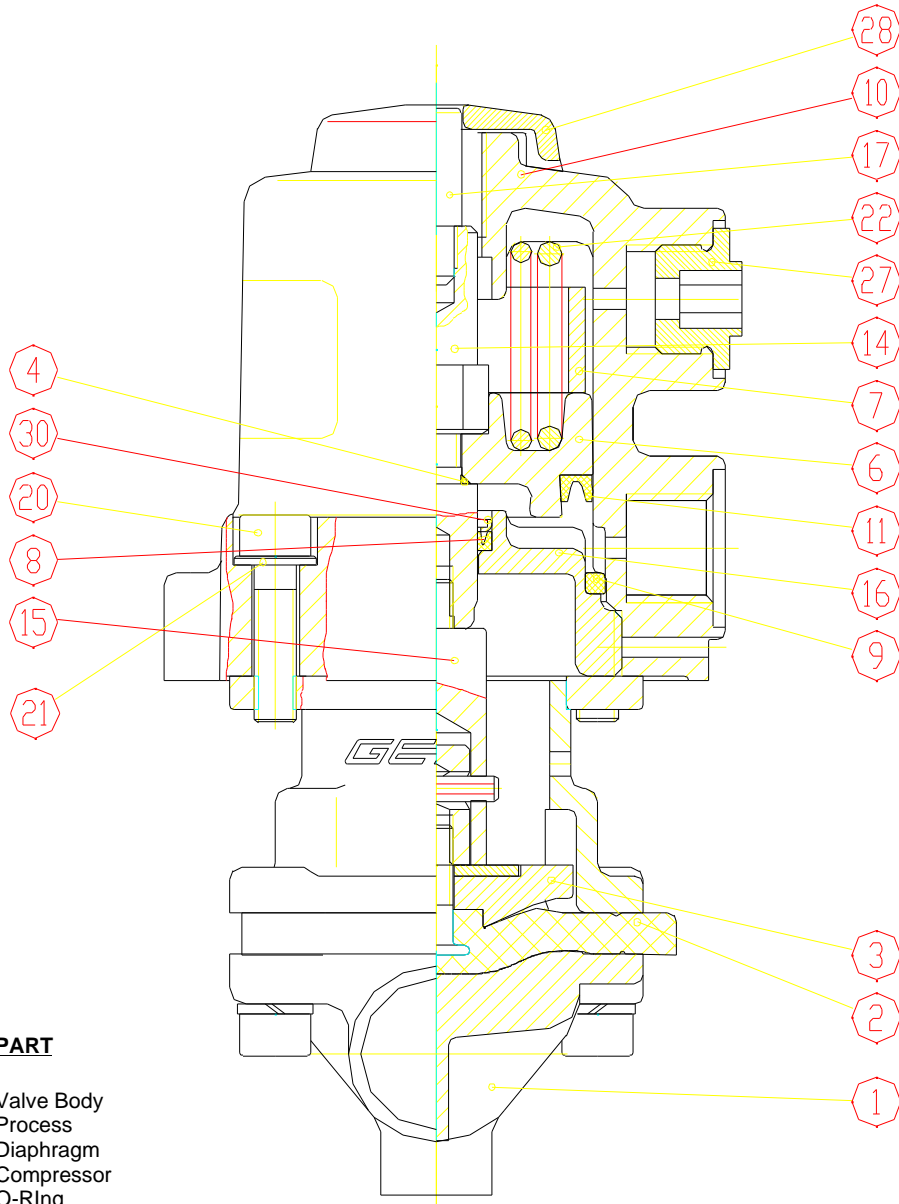

ITEM	PART
1	Valve Body
2	Process Diaphragm
3	Compressor
4	O-Ring
6	Piston
7	Distance Ring
8	Lip Ring
9	O-Ring
10	Actuator Housing
11	Lip Ring
14	Spindle
15	Spindle
16	Guide Piece
17	Indicator
18	Nut
19	Washer
20	Bolt
21	Washer
22	Spring
25	Distance Piece
26	Spring
27	Plug
28	Cap
29	Stroke Limiter (accessory)
30	Safety Disk



GESINT®

GESINT S.R.L.

Via Perosi, 5

20010 Bareggio (MI) - ITALY

Tel. 02/9014633 - 335/6282615

Fax 02/90362295

e-mail: info@gesintsrl.it

WWW.GESINTSRL.IT