

The compact ultra-low flow sensor type ULF is designed for use with every kind of aggressive and solid-free liquids. The sensor can be fixed to flexible or rigid pipes via 1/4" GAS threaded process connections. The paddlewheel sensor produces a frequency output proportional to the flow velocity that can be easily transmitted and processed. The ULF sensor offers two different flow ranges starting from 1.5 or 6 l/h (0.0066 or 0.0264 gpm). The construction materials, POM or ECTFE (Halar®), provide high strength and chemical resistance.

Main Features

- POM or ECTFE (Halar®) wetted parts.
- Two flow ranges available:
 - 1.5 - 100 l/h (0.0066 - 0.44 gpm)
 - 6 - 250 l/h (0.0264 - 1.1 gpm).
- High chemical resistance.
- Easy mounting.
- 4-20 mA output.
- MIN alarm relay output.

Applications

- Water treatment.
- Chemical industry.
- Pharmaceutical industry.
- Dosing systems.
- Laboratory plants.

Technical Features

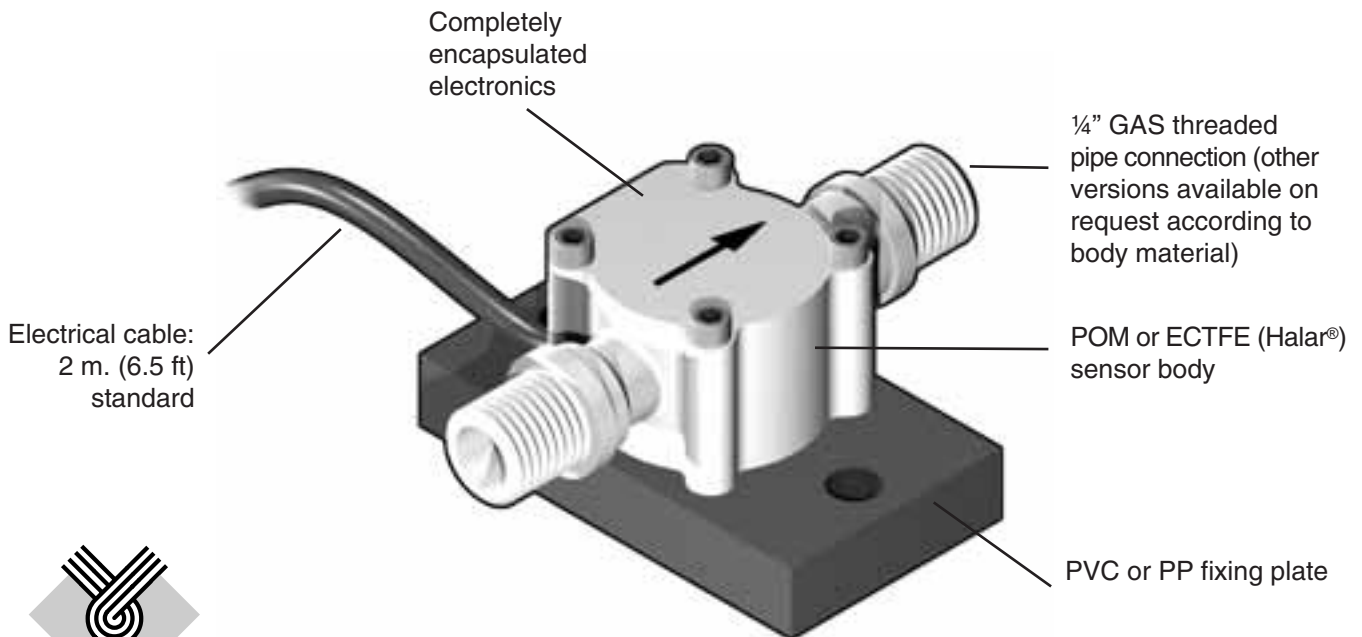

Operating principle

The flow sensor consists of a transducer and a paddlewheel with a permanent magnet integrated into each blade. As the magnet passes close to the transducer a pulse is generated.

When liquid flows into the sensor body, the paddlewheel is set in rotation producing a square wave output signal. The frequency is proportional to the flow velocity.

Engineering Data

- The flow sensor is available with Hall effect transducer (standard) and Reed effect transducer (battery operated).
- The Hall sensor operates with a power supply from 5 to 24 VDC @ < 15 mA.
- The Reed sensor requires no power supply.
- The standard output signal is a square wave output with frequency proportional to flow velocity.
- The output signal is provided directly via electric cable. Supplied cable is standard 2 m (6.5 ft) long.
- In the versions with 4-20 mA or MIN alarm output, an additional IP65 housing is added to the sensor. Output signals are available on a terminal strip inside via a PG 11 cable gland.
- The sensor ULF3.30 with 4-20 mA output and the sensor ULF3.15 with MIN alarm output require a power supply from 12 to 24 VDC.
- The nominal measuring ranges are from 1.5 to 100 l/h (0.0066 to 0.44 gpm) for ULF01 version and from 6 to 250 l/h (0.0264 to 1.1 gpm) for ULF03 version.

Connections to FlowX3 Instruments

FLOWX3 Sensors	FLOWX3 Instruments					
	F9.00	F9.01	F9.02	F9.03	F9.20	F9.50
ULF01.H		■	■	■		■
ULF01.R	■				■	
ULF03.H		■	■	■		■
ULF03.R	■				■	
ULF3.15*		■	■	■		■
ULF3.30*						

* with Output Kit mounted.

Dimensions

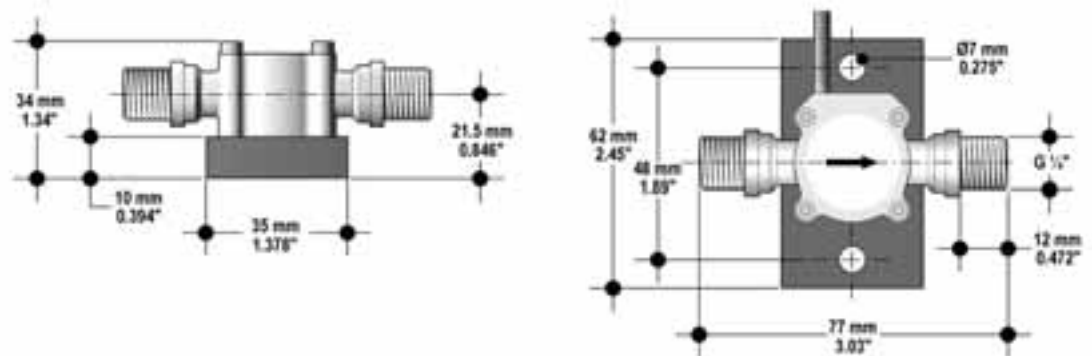

Installation Guidelines

- The sensor can be installed in any position, both horizontally or vertically, although horizontal flow is preferred. A non horizontal installation may cause a greater error in the lower part of the measurement range.
- Install the sensor with the arrow pointing the direction of the flow.
- Always maximize distance between sensor and pump. Do not install the sensor immediately downstream of valves, elbows or any kind of obstacles: 150 mm of straight pipe are suggested before and after the sensor.

Wiring

ULFXX.H Sensor Connection to FLOWX3 Instruments



ULFXX.H Sensor Connection to other instruments

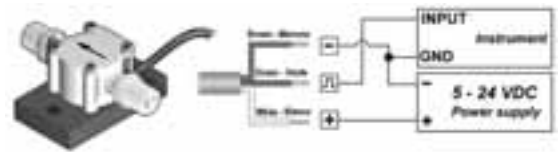

ULFXX.R Sensor Connection to FLOWX3 Instruments



ULFXX.R Sensor Connection to other instruments

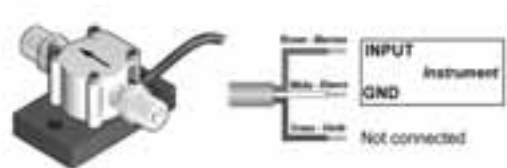

Technical Data

General (Hall and Reed)

- Flow Rate Range:
 - ULF01 version: 1.5 to 100 l/h (0.0066 to 0.44 gpm)
 - ULF03 version: 6 to 250 l/h (0.0264 to 1.1 gpm).
- Linearity: $\pm 1\%$ of full scale.
- Repeatability: $\pm 0.5\%$ of full scale.
- Working Temperature: -10°C to 80°C (14°F to 176°F)
- Working Pressure: 5 bar (70 psi) max @ 22°C (72°F).
- Viscosity of fluid: 1 to 10 cST.
- Enclosure: IP65.

- Wetted materials:
 - POM version:
 - Sensor Body: POM
 - O-ring: FPM
 - Rotor: POM
 - Shaft: corepoint
 - Magnets: ceramic.
 - ECTFE version:
 - Sensor Body: ECTFE (Halar[®])
 - O-ring: FPM or KALREZ
 - Rotor: ECTFE (Halar[®])
 - Shaft: Sapphire
 - Bearings: Sapphire.
- Connections: $\frac{1}{4}$ " GAS male threaded.
- Cable length: 2 m (6.5 ft) standard.

Standards & Approvals

- Manufactured under ISO 9001 (Quality).
- CE Conformity.

Specific for ULF01.H / ULF03.H (Hall version)

- Supply voltage: 5 to 24 VDC $\pm 10\%$, regulated.
- Supply current: $< 15\text{ mA}$ @ 24 VDC.
- Output signal: square wave.

- K-factor:
 - ULF01 version: 8431 Pulses/Liter (31569 Pulses/U.S. Gallon) in linear range from 8 to 100 l/h
 - ULF03 version: 3394 Pulses/Liter (12846 Pulses/U.S. Gallon) in linear range from 15 to 250 l/h.

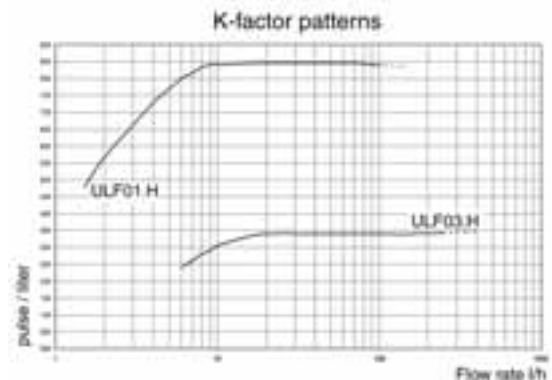
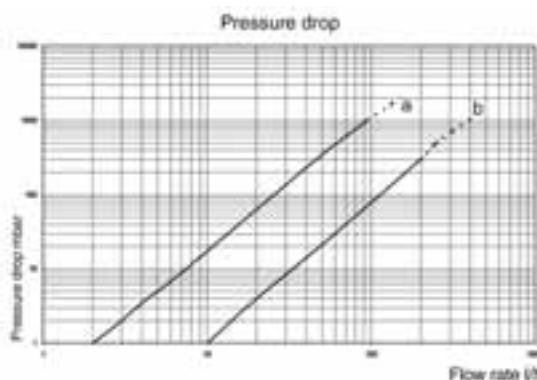

Technical Data

Specific for ULF01.R / ULF03.R (Reed version)

- Supply voltage: none.
- Output signal: square wave.
- Output type: Reed Contact.

■ K-factor:

- ULF01 version: 2108 Pulses/Liter (7978 Pulses/U.S. Gallon) in linear range from 8 to 100 l/h.
- ULF03 version: 848 Pulses/Liter (3210 Pulses/U.S. Gallon) in linear range from 15 to 250 l/h.

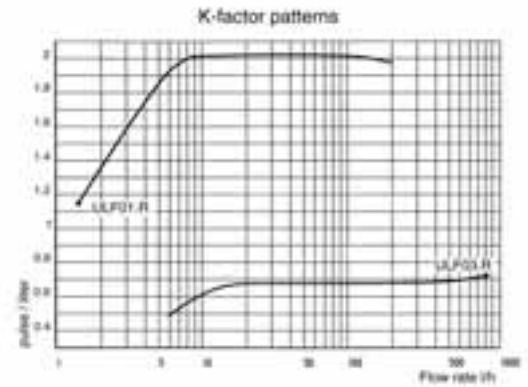
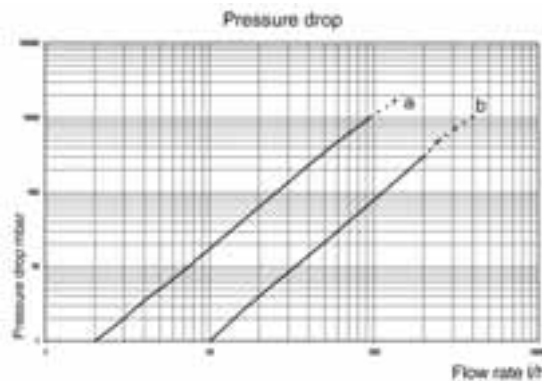

Output Devices

K315U - Frequency Output & MIN alarm KIT

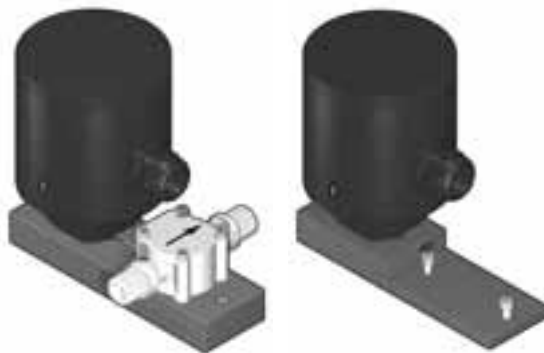

This Kit consists of an additional IP65 housing mounted aside the sensor via a PVC plate. It is equipped with an open collector frequency output and a mechanical SPDT contact. The MIN alarm set-point can be freely set by a potentiometer up to 21 l/h (0.09 gpm) for ULF01 and 53 l/h (0.23 gpm) for ULF03. When the flow velocity drops below the adjusted limit the relay output opens and the Local Status Indicator changes colour. It has been designed to protect a pump from running dry or pumping against a closed valve in the main pipeline.

Main Features

- Highly visible Local Bicolour Status Indicator.
- Easy and quick threshold regulation.
- Open collector frequency output.
- Relay output mechanical SPDT.

Applications

- Pump protection.
- Water treatment.
- Cooling water systems.

Dimensions K315U KIT

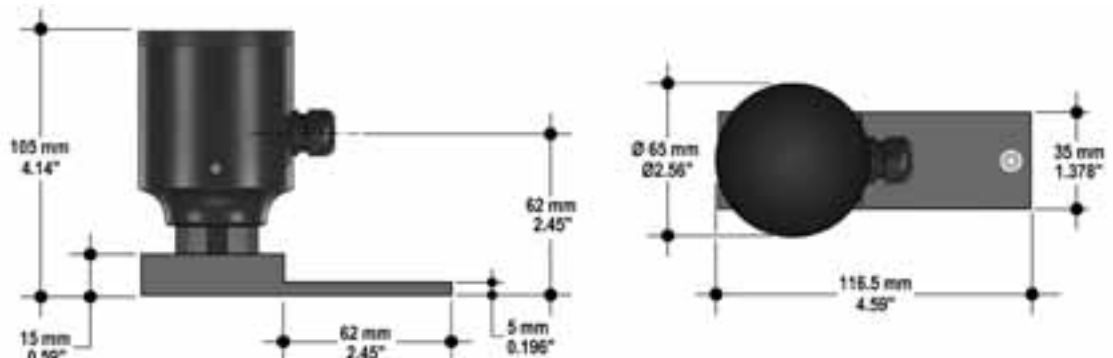

Output Devices

Dimensions ULF3.15 Sensor with O.C. output & MIN alarm

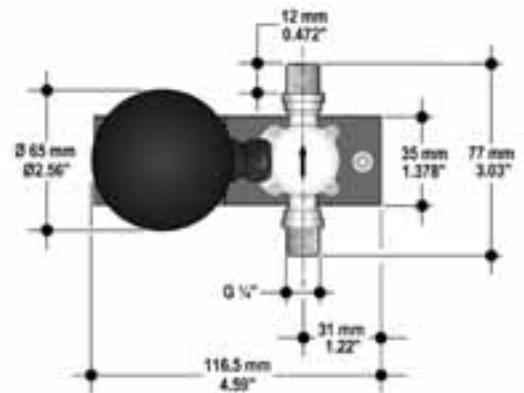
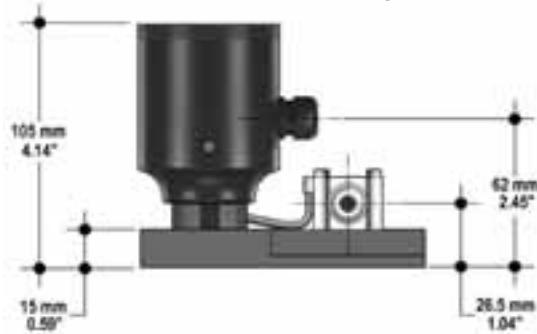

Wiring and Operation

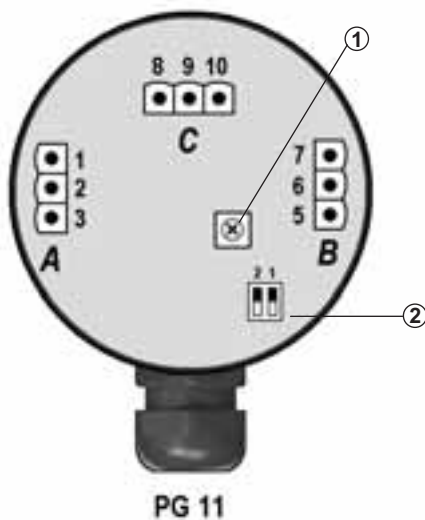

Power Supply	
A	1 +12-24 VDC
	2 FREQ. OUTPUT
	3 GND

SENSOR	
B	7 V+
	6 IN
	5 GND

RELAY	
C	8 NO
	9 NC
	10 COM

- 1) Calibration trimmer for MIN alarm set-point
- 2) Setting switches

The output module is characterized by two operation modes:

- Calibration mode
- Switch 1 is in OFF position and the MIN set-point is fixed by acting on the trimmer.

- Operative mode
- Switch 1 is in ON position and the module ready to work
- Switch 2 can be used to select the most suitable switch delay (3 seconds or 10 seconds).

Technical Data

- Associated Flow Sensor: Hall effect (ULFXX.H).
- Supply voltage: 12 to 24 VDC $\pm 10\%$, regulated.
- Output signal: square wave.
- Output type: transistor NPN open collector.
- Output current: 10 mA max.
- Relay Output: mechanical SPDT contact, 3 A @ 30 VDC, 3 A @ 230 VAC resistive load.
- Flow trip point: freely adjustable
 - up to 21 l/h (0.09 gpm) for ULF01
 - up to 53 l/h (0.23 gpm) for ULF03.

- Local Status Indicator: GREEN Led = Flow, RED Led = No Flow.
- Enclosure: IP65.
- Operating temperature: 0°C to 60°C (32°F to 140°F).
- Relative humidity: 0 to 95% non-condensing.
- Housing material: PVC.

Standards & Approvals

- Manufactured under ISO 9001 (Quality).
- CE Conformity.

Output Devices

K330U – 4-20 mA Output KIT

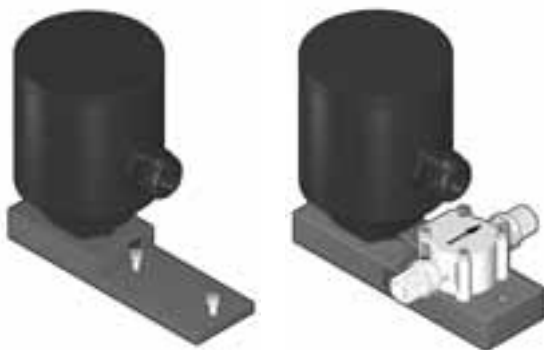

This Kit consists of an additional IP65 housing mounted aside the sensor via a PVC plate. It is a blind transmitter designed to convert the signal from the sensor into a 4-20 mA output for long distance transmission.

Main Features

- Easy 4-20 mA output calibration.
- Three wire output technology.

Applications

- Flow control and monitoring.
- Water treatment.
- Dosing systems.

Dimensions

K330U KIT

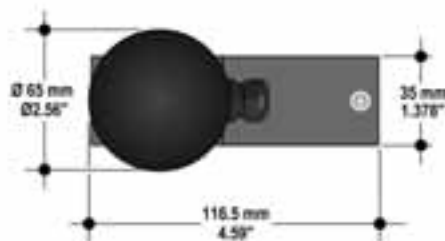
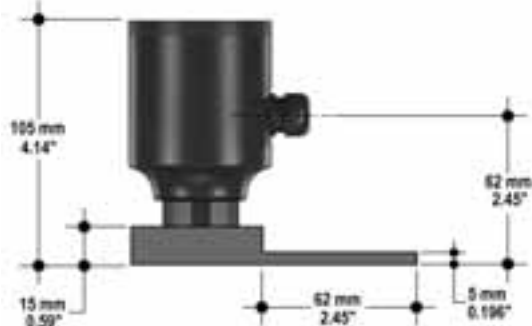

ULF3.30 Sensor with 4-20 mA Output

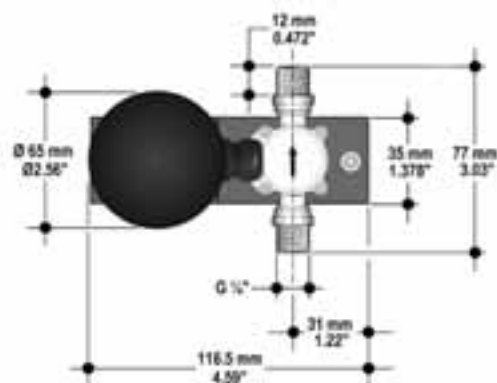
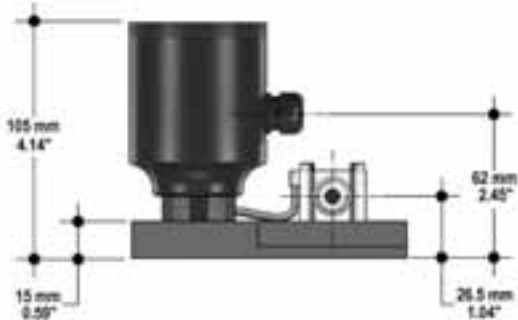

Output Devices

Wiring and Operation

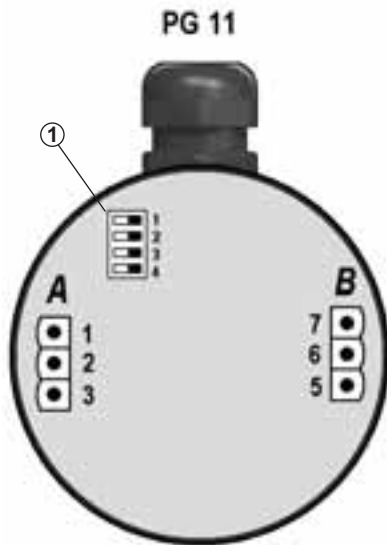

Power Supply	
A 1	+12-24VDC
2	4-20 mA OUTPUT
3	GND

SENSOR	
B 7	V+
6	IN
5	GND

1) Calibration switch.

The full scale range, corresponding to 4-20 mA output is set by means of switches 2, 3 and 4.

Switch 1 is used to set a filter on the current output.

Technical Data

- Associated Flow Sensor: Hall effect (ULFXX.H).
- Supply voltage: 12 to 24 VDC $\pm 10\%$, regulated.
- Supply current: < 50 mA.
- Output signal: 4 to 20 mA, adjustable.
- Max load impedance: 800 Ω @ 24 VDC, 300 Ω @ 12 VDC.
- Enclosure: IP65.

- Operating temperature: 0°C to 60°C (32°F to 140°F).
- Relative humidity: 0 to 95% non-condensing.
- Housing material: PVC.

Standards & Approvals

- Manufactured under ISO 9001 (Quality).
- CE Conformity.

Output Devices

Installation

The K315U and K330U Kits can be ordered directly mounted aside the flow sensor or separately and then simply installed on the proper sensor.

Please refer to Ordering Data section for a complete listing of part numbers.

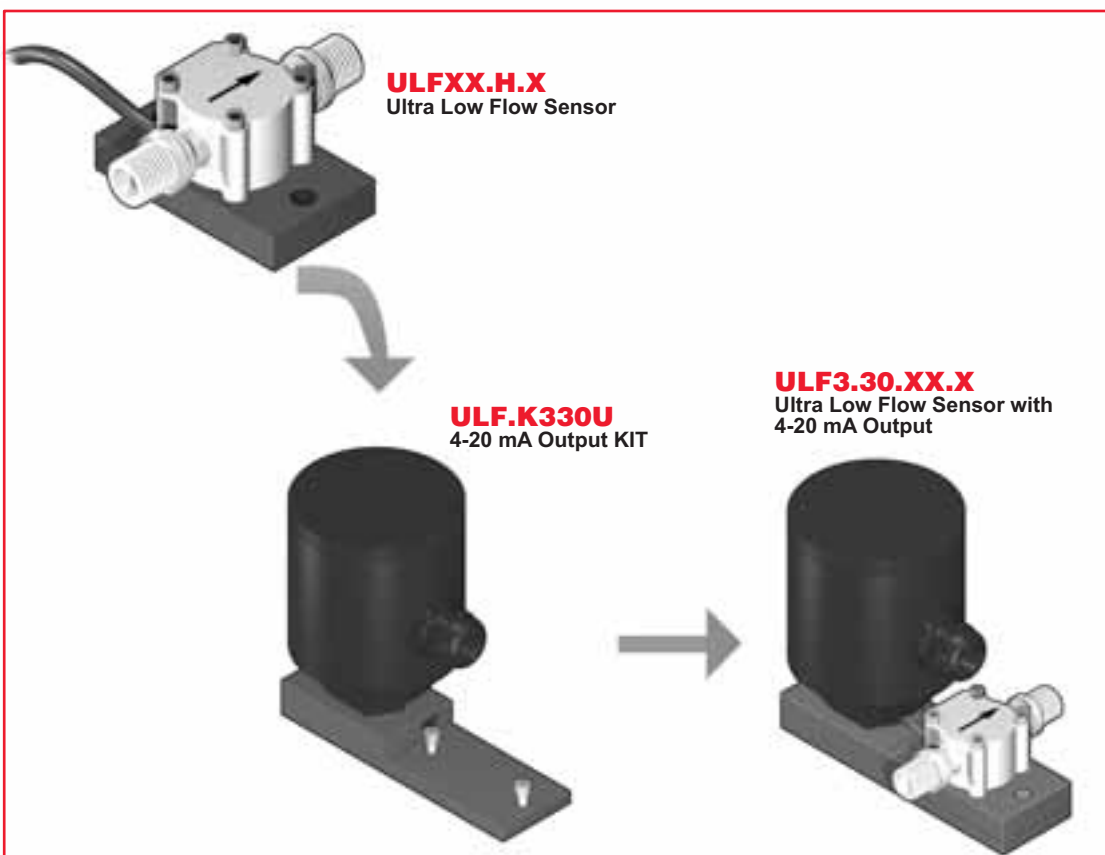
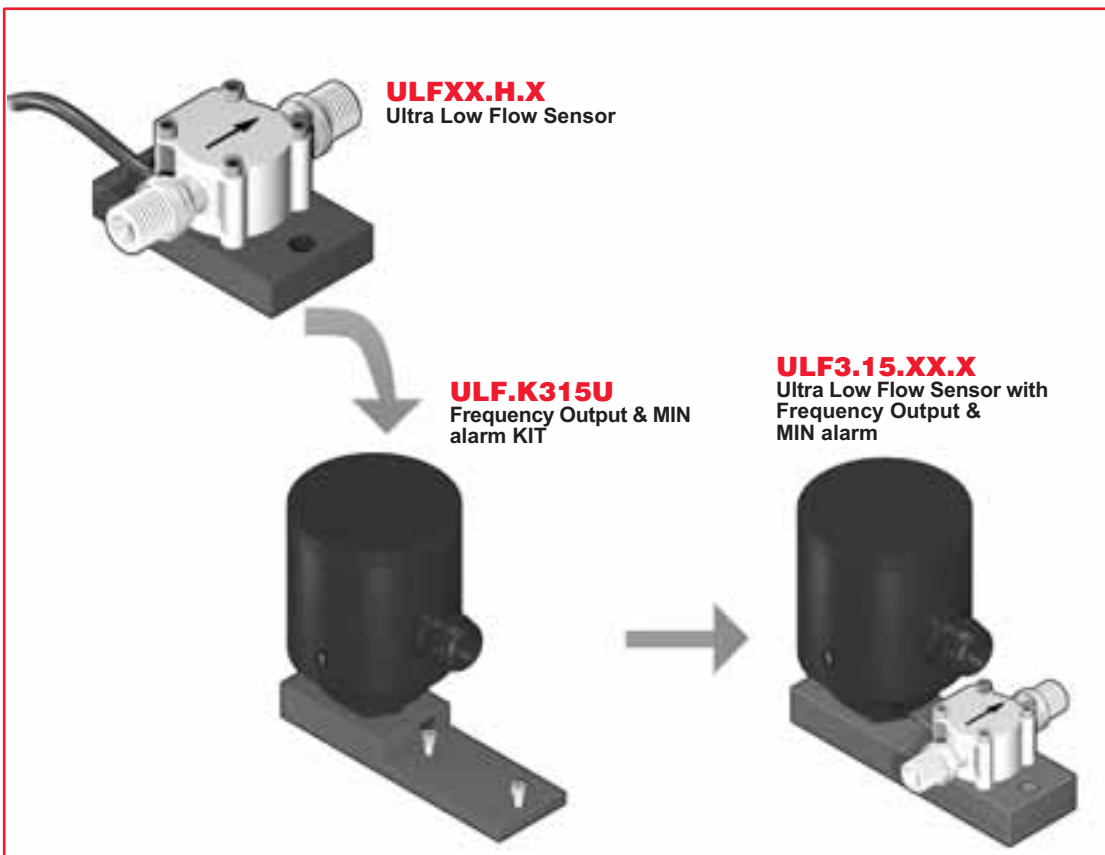

Ordering Data

FLOWX3 ULF01.X.X

Part No.	Version	Power supply	Material	Flow Rate Range
ULF01.H.0	Hall	5 - 24 VDC	POM / FPM	1.5 to 100 l/h (0.0066 to 0.44 gpm)
ULF01.H.2	Hall	5 - 24 VDC	ECTFE / FPM	1.5 to 100 l/h (0.0066 to 0.44 gpm)
ULF01.H.3	Hall	5 - 24 VDC	ECTFE / KALREZ	1.5 to 100 l/h (0.0066 to 0.44 gpm)
ULF01.R.0	Reed	None	POM / FPM	1.5 to 100 l/h (0.0066 to 0.44 gpm)
ULF01.R.2	Reed	None	ECTFE / FPM	1.5 to 100 l/h (0.0066 to 0.44 gpm)
ULF01.R.3	Reed	None	ECTFE / KALREZ	1.5 to 100 l/h (0.0066 to 0.44 gpm)

FLOWX3 ULF03.X.X

Part No.	Version	Power supply	Material	Flow Rate Range
ULF03.H.0	Hall	5 - 24 VDC	POM / FPM	6 to 250 l/h (0.0264 to 1.1 gpm)
ULF03.H.2	Hall	5 - 24 VDC	ECTFE / FPM	6 to 250 l/h (0.0264 to 1.1 gpm)
ULF03.H.3	Hall	5 - 24 VDC	ECTFE / KALREZ	6 to 250 l/h (0.0264 to 1.1 gpm)
ULF03.R.0	Reed	None	POM / FPM	6 to 250 l/h (0.0264 to 1.1 gpm)
ULF03.R.2	Reed	None	ECTFE / FPM	6 to 250 l/h (0.0264 to 1.1 gpm)
ULF03.R.3	Reed	None	ECTFE / KALREZ	6 to 250 l/h (0.0264 to 1.1 gpm)

FLOWX3 ULF3.15.XX.X (with O.C. output & MIN alarm)

Part No.	Version	Power supply	Material	Flow Rate Range
ULF3.15.01.0	Hall	12 - 24 VDC	POM / FPM	1.5 to 100 l/h (0.0066 to 0.44 gpm)
ULF3.15.01.2	Hall	12 - 24 VDC	ECTFE / FPM	1.5 to 100 l/h (0.0066 to 0.44 gpm)
ULF3.15.01.3	Hall	12 - 24 VDC	ECTFE / KALREZ	1.5 to 100 l/h (0.0066 to 0.44 gpm)
ULF3.15.03.0	Hall	12 - 24 VDC	POM / FPM	6 to 250 l/h (0.0264 to 1.1 gpm)
ULF3.15.03.2	Hall	12 - 24 VDC	ECTFE / FPM	6 to 250 l/h (0.0264 to 1.1 gpm)
ULF3.15.03.3	Hall	12 - 24 VDC	ECTFE / KALREZ	6 to 250 l/h (0.0264 to 1.1 gpm)

FLOWX3 ULF3.30.XX.X (with 4-20 mA output)

Part No.	Version	Power supply	Material	Flow Rate Range
ULF3.30.01.0	Hall	12 - 24 VDC	POM / FPM	1.5 to 100 l/h (0.0066 to 0.44 gpm)
ULF3.30.01.2	Hall	12 - 24 VDC	ECTFE / FPM	1.5 to 100 l/h (0.0066 to 0.44 gpm)
ULF3.30.01.3	Hall	12 - 24 VDC	ECTFE / KALREZ	1.5 to 100 l/h (0.0066 to 0.44 gpm)
ULF3.30.03.0	Hall	12 - 24 VDC	POM / FPM	6 to 250 l/h (0.0264 to 1.1 gpm)
ULF3.30.03.2	Hall	12 - 24 VDC	ECTFE / FPM	6 to 250 l/h (0.0264 to 1.1 gpm)
ULF3.30.03.3	Hall	12 - 24 VDC	ECTFE / KALREZ	6 to 250 l/h (0.0264 to 1.1 gpm)

Ordering Data

Output Devices

Part No.	Housing	Gaskets	Enclosure	Description
ULF.K315U	PVC	EPDM	IP65	Frequency Output & MIN Alarm KIT
ULF.K330U	PVC	EPDM	IP65	4-20 mA Output KIT

Spare Parts

Item	Part No.	Name	Description
1	ULF.SP1U	PVC Plate	PVC Adapter for K315U or K330U Kit
	F3.SP6	Electrical cable	Cable (per meter), 22AWG, 3 cond.
2	F3.SP7	PG11	PG11 Cable Gland for K315U or K330U Kit

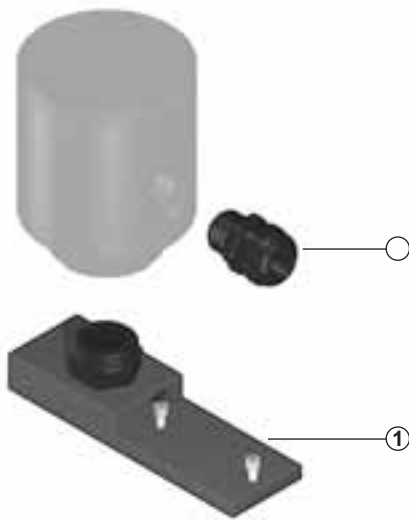

GESINT S.R.L.

Via Perosi, 5

20010 Bareggio (MI) - ITALY

Tel. 02/9014633 - 335/6282615

Fax 02/90362295

e-mail: info@gesintsrl.it

WWW.GESINTSRL.IT