



K330 - 4-20mA Output KIT for Paddlewheel Flow Sensor

INSTRUCTION MANUAL

EN 05-03

Table of Contents

1. Introduction.....	2
1.1. Safety Instructions.....	2
1.2. Unpacking.....	2
2. Description.....	2
3. Specifications.....	3
3.1. Technical Data.....	3
3.2. Dimensions.....	3
4. Installation.....	4
4.1. Sensor Assembly.....	4
4.2. Wiring.....	4
5. Calibration.....	6
5.1. Full Scale Setting.....	6
5.2. Filter Setting.....	7
6. Troubleshooting.....	7
7. Ordering Data.....	7

1. Introduction



1.1. Safety Instructions

General Statements

- ❑ Do not install and service the device without following the Instruction Manual.
- ❑ This unit is designed to be connected to other instruments which can be hazardous if used improperly. Read and follow all associated instrument manuals before using with this sensor.
- ❑ Installation and wiring connections should only be performed by qualified staff.
- ❑ Do not modify product construction.

Installation and Commissioning Statements

- ❑ Remove power to the device before wiring any connection.
- ❑ When the unit is powered and the cover is open, protection against electric shocks is not ensured.
- ❑ Do not exceed published specifications using this instrument.
- ❑ To clean the device, use only chemical compatible products.

1.2. Unpacking

Please verify that the product is complete and without any damage. The following items must be included:

- K330 – 4-20mA Output KIT for Paddlewheel Flow Sensor with black sensor cap included
- Instruction Manual

2. Description



This Kit consists of an additional IP65 housing plugged on the sensor. It is a blind transmitter designed to convert the signal from the sensor into a 4...20 mA signal for long distance transmission.

3. Specifications

3.1. Technical Data

Associated Flow Sensor: Hall effect (F3.01.H.XX Compact version)

Supply voltage: 12 to 24 VDC regulated

Supply current: < 50 mA

Output signal: 4 to 20 mA, adjustable

Max load impedance: 800 Ω @ 24 VDC, 300 Ω @ 12 VDC

Enclosure: IP65

Operating temperature: 0 to 60°C (32 to 140°F)

Relative humidity: 0 to 95% non-condensing

Housing material: PVC

Standards & Approvals

Manufactured under ISO 9002

CE rating according to:

- Immunity: EN50082-1
- Emission: EN61000-6-2
- Low Voltage Directive : EN61010

3.2. Dimensions

K330 KIT

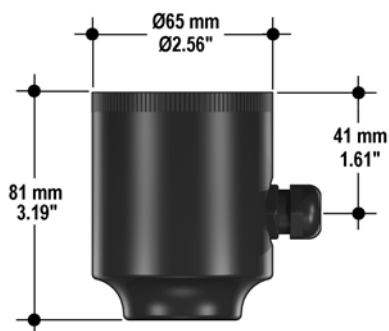

F3.30 Sensor with 4 –20mA Output

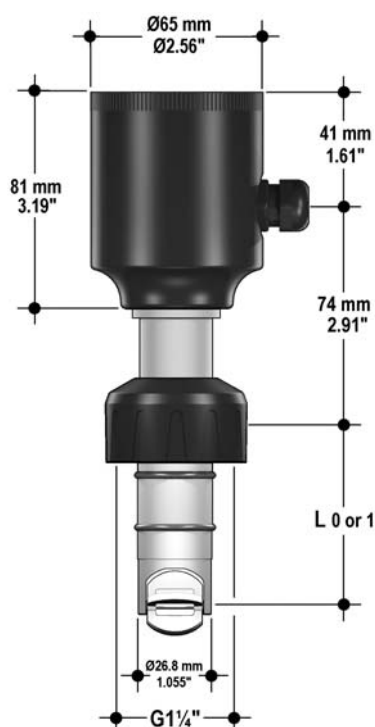

L0 = 68.3 mm (2.69 in)

L1 = 98.5 mm (3.88 in)

4. Installation

4.1. Sensor Assembly

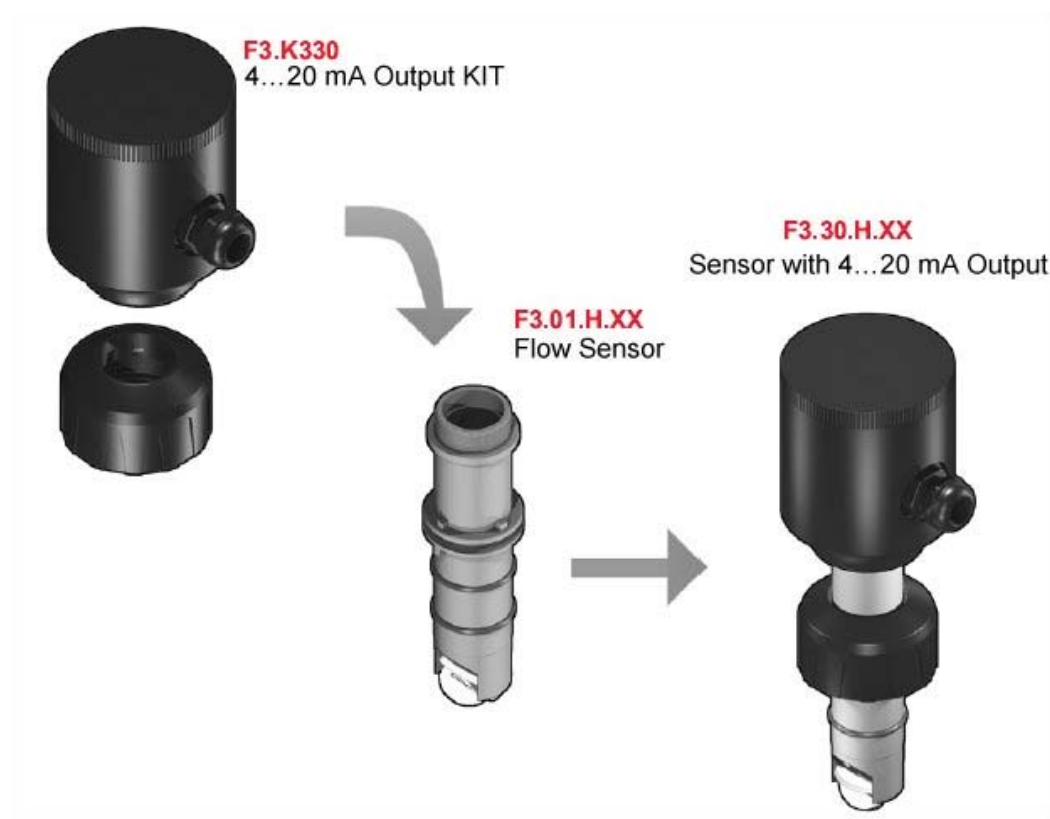

Screw down completely the electronic box to have a perfect sealing between the sensor and the box.

4.2. Wiring

Unscrew the top cover to reach the electrical connections. All wiring connections to K3.30 are made via removable terminals.

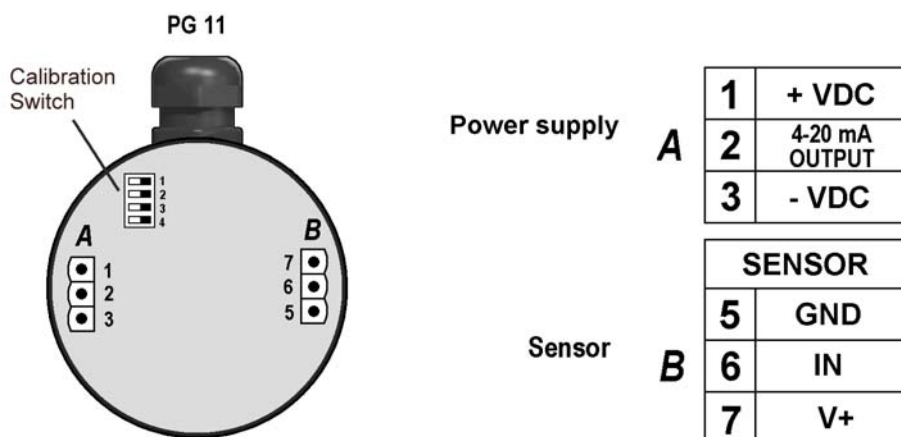



General recommendation

- ❑ Always ensure the power supply is switched off before working on the device.
- ❑ Terminals accept 26 to 12 AWG (0.08 to 2.5 mm²)
- ❑ Strip around 10 mm (0.4") of insulation from the wire tips and tin bare ends to avoid fraying.
- ❑ Ferrules are suggested when connecting more than one wire to a single terminal.
- ❑ Remove the upper part of the terminals for an easy cabling.
- ❑ Insert wire tip or ferrule completely into the terminal and fix with the screw until finger tight

Power/Loop Wiring Diagram

Connection to PLC with built-in power supply

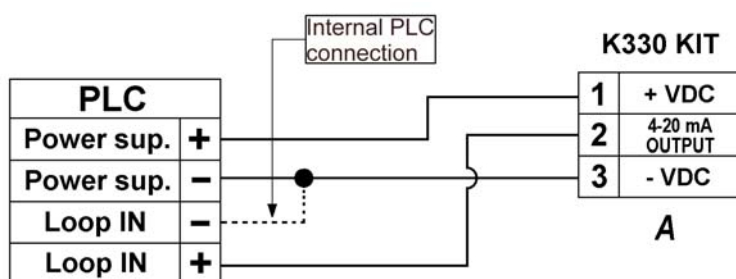

Connection to PLC / Instrument with separate power supply

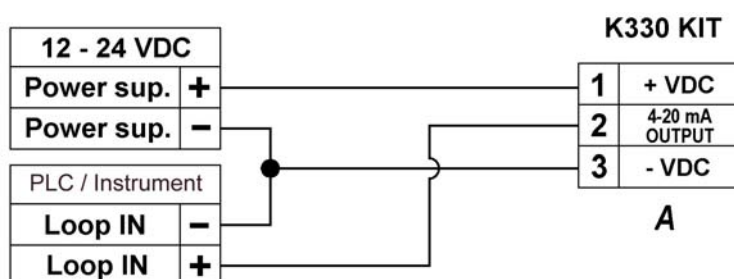

Sensor Wiring Diagram



F 3.01.H. XX

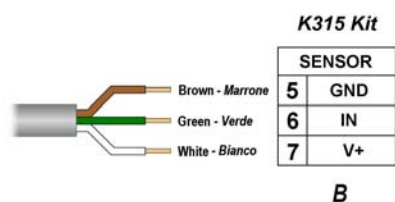

5. Calibration

The setting has to be done before powering up the instrument.

5.1. Full Scale Setting

The Full Scale value, corresponding to 20mA output, can be set from 50 to 400 Hz and is calibrated by means of the 2, 3 and 4 switches according to the following table:

SWITC H 2	SWIT CH 3	SWIT CH 4	Hz
ON	ON	ON	50
ON	ON	OFF	75
ON	OFF	ON	100
ON	OFF	OFF	150
OFF	ON	ON	200
OFF	ON	OFF	300
OFF	OFF	ON	400

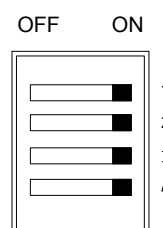

Full Scale Frequency calculation

Use the following formula

$$\text{Freq} = \frac{Q \text{ (l/h) } \times \text{K-Factor}}{t \text{ (s)}} \text{ [Hz]}$$

Freq = frequency .

Q is the max. flow rate in l/h

t is the time is seconds

K-Factor is unique to the sensor model and to the pipe size and material. Refer to data in the sensor manual for the correct value.

Example:

Consider a PVC ISO pipe D32 (1").

K-Factor = 91.53

Qmax = 4000 l/h (max. flow rate you may have in the plant)

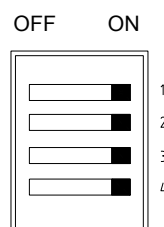

$$\text{Freq} = \frac{4000 \times 91.53}{3600} = 88.99 \text{ Hz}$$

The full scale frequency to be set is 100 Hz

5.2. Filter Setting

The filter prevents fluctuations of the output current. There are two levels available according to the position of switch 1.

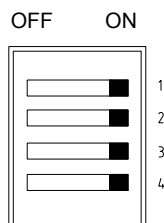

Switch 1

OFF : low filter

ON : high filter

6. Troubleshooting

Problem	Reason	Solution
No output signal	<ul style="list-style-type: none"> No or wrong power supply Incorrect cabling 	Verify : <ul style="list-style-type: none"> Power supply (sec. 4.2. Wiring) Correct wire insertions into terminal holes (sec. 4.2. Wiring)
Incorrect current output	Wrong full scale setting	Verify switch positions (sec. 5. Calibration)

7. Ordering Data

Part No.	Housing	Gaskets	Enclosure	Description
F3.K330	PVC	EPDM	IP65	4-20 mA Output KIT



GESINT.

GESINT S.R.L.

Via Perosi, 5

20010 Bareggio (MI) - ITALY

Tel. 02/9014633 - 335/6282615

Fax 02/90362295

e-mail: info@gesintsrl.it

WWW.GESINTSRL.IT