



CP-2R

Magnet passage detector
Seam detector



Technical data

Power supply:	24VAC/DC switching
Power consumption:	2VA / 1,8W max
Amplification:	from 10^3 to 3×10^5
Input:	1 or 2 AC/DC coil
Output:	2 SPDT relays
Contact rating:	7A @ 250 VAC (resistive load) 3A @ 230 VAC (inductive load)
Pulse duration:	from 0,5 to 2,5 seconds adjustable
Adjustments:	2 trimmers for sensitivity 1 trimmer for pulse duration
Programming:	Using dip-switch
Visual signaling:	Green LED → Power supply Red LED → Magnet detection
Installation:	35 mm DIN rail
Electrical connection:	Removable terminal board
Protection:	IP20
Storage temperature:	from -30 to +80°C
Working temperature:	from -20 to +60°C
Relative humidity:	from 0 to 85%, no condensate
Dimensions:	90(H) x 35(L) x 60(P) mm

CE mark according to *Directive 89/336/CEE*, complies with the following harmonised regulations: *EN50081-1, EN 50082-2, EN55022, EN61000-4-2, EN61000-4-3, EN61000-4-4, EN61000-4-5, EN61000-4-6, EN61000-4-11* and *Low Voltage Directive 73/23/CEE* and subsequent modifications.

Overview

CP-2R is an instrument capable of detecting the passage of a magnet near an inductance, activating the output relays. On dyeing machines, it is used for seam detection during tissue unload operation or for measuring the speed of the tissue inside the machine.

Electrical connections

Power Supply: 24 VAC/DC

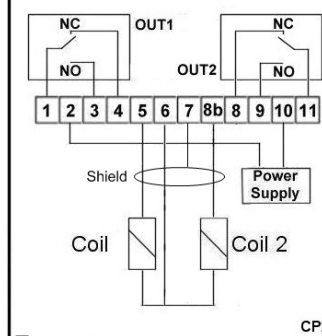

It is recommended to use a connection cable of at least 0,5mmq section, trying to minimise the length of inductance cables. Connection cables must have separate run from power cables.

In order to reduce the influence of jamming created by external electromagnetic fields, it is mandatory to use a shielded cable for connecting the inductance and connect the shield on one side only, to pin No.7. The inductance have to be connected to pin No.5 and 6 and an additional inductance have to be connected to pin No.6 and 8B.

Warranty

The warranty is valid for 12 months from purchase, and expires if instrument is improperly used or not correctly installed on system.

Operation and calibration

It is recommended to install the instrument on the board as far as possible from other instruments that may create electromagnetic field, such as inverter, and in every case keep the detector at least 2cm far from other instruments. It is possible to adjust relay pickup time when magnet passage is detected using the "Pulse" trimmer, while the inductance sensitivity is adjustable using the "B1" and "B2" trimmers.

The main factors that can influence the capability of the instrument to detect a magnet passage are:

- magnetic field generated by the used magnet

it is recommended to use AlNiCo or Neodymium magnets and, in case of difficult detection, try magnets with different size and shape or try to change the inductance orientation.

- the maximum distance between inductance and magnet

if you need to increment the maximum detection distance, you can adjust on the sensibility trimmer, but note that with higher sensibility the instrument become more sensible to external noise. If you are using it with PTFE coated magnets Mod. IMA, maximum recommended distance between inductance and magnet is 15cm with minimum amplification and 30cm with maximum amplification.

- turns quantity in the used inductance

the instrument is compatible with inductance from 50Ω to 5000Ω (e.g.. Inductance of solenoid valve with AC or DC power supply).

- strong electromagnetic field near the inductance

it is recommended to place the inductance as far as possible from noise source as transformers, electric motors or pumps, and eventually to shield the exposed sides of the inductance with a metal grid.



GESINT.

WWW.GESINTSRL.IT

GESINT S.R.L.

Via Perosi, 5
20010 Bareggio (MI) - ITALY
Tel. +39-02-9014633
Mob. +39-335-6282615
Fax +39-02-90362295
E-mail: info@gesintsrl.it