

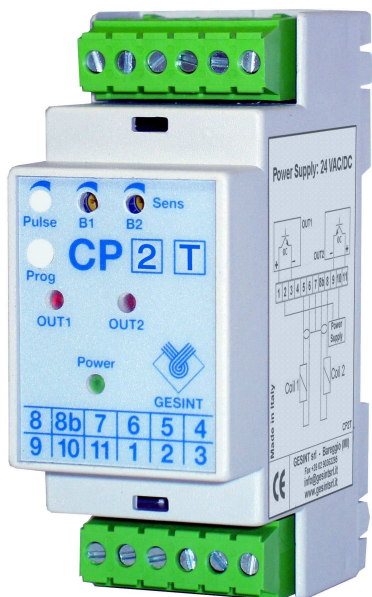

# CP-2T

Magnet passage detector  
Idle roller rotation speed



## Caratteristiche tecniche

Power supply:	<b>24VAC/DC switching</b>
Power consumption:	2VA / 1,8W max
Amplification:	form $10^3$ to $3 \times 10^5$
Input:	1 or 2 AC/DC coil
Max input frequency:	20 Hz
Output:	2 Open Collector NPN/PNP with opto-coupler
Max current:	50 mA
Max pull-up voltage:	24 VDC
Pulse time:	from 0,04 to 0,8 sec. proportional to input frequency
Adjustments:	2 trimmer for sensitivity
Visual signaling:	Green LED → Power supply Red LED → Magnet detection
Installation:	35 mm DIN rail
Electrical connection:	Removable terminal board
Protection:	IP20
Storage temperature:	from -30 to +80°C
Working temperature:	from -20 to +60°C
Relative humidity:	from 0 to 85%, no condensate
Dimensions:	90(H) x 35(L) x 60(P) mm

**CE** mark according to *Directive 89/336/CEE*, complies with the following harmonised regulations: *EN50081-1*, *EN 50082-2*, *EN55022*, *EN61000-4-2*, *EN61000-4-3*, *EN61000-4-4*, *EN61000-4-5*, *EN61000-4-6*, *EN61000-4-11* and *Low Voltage Directive 73/23/CEE* and subsequent modifications.

## Overview

CP-2T is an instrument capable of detecting the passage of a magnet near an inductance, generating an impulse on the transistor output. On dyeing machines, it is used for measuring the rotation speed of the idle roller or for measuring the speed of the tissue inside the machine.

## Electrical connections

### Power Supply: 24 VAC/DC

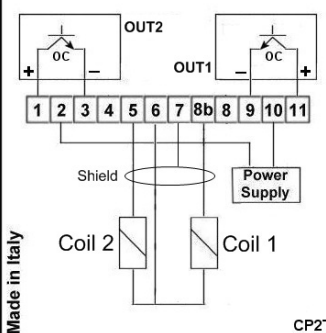

It is recommended to use a connection cable of at least 0,5mmq section, trying to minimise the length of inductance cables. Connection cables must have separate run from power cables.

In order to reduce the influence of jamming created by external electromagnetic fields, it is mandatory to use a shielded cable for connecting the inductance and connect the shield on one side only, to pin No.7. At the inductance connected to pin No.5 and 6 is linked output OUT2, while the inductance connected to pin No.6 (shared between coils) and 8B is linked to OUT1. In order to connect the instrument to a PLC or another instrument with PNP or NPN digital input it is recommended to follow these schemas:

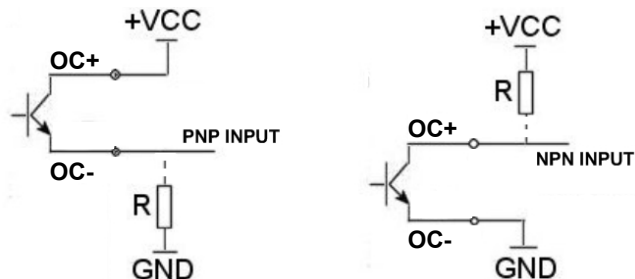

If connected directly to a PLC with PNP/NPN input, the resistance R is internal to the PLC. In case of generic digital input, the pull-up resistor R must be installed externally and scaled so that on the transistor the current never exceed 50mA (recommended values from 1KΩ to 10KΩ).

## Operation and calibration

It is recommended to install the instrument on the board as far as possible from other instruments that may create electromagnetic field, such as inverter, and in every case keep the detector at least 2cm far from other instruments. It is possible to adjust the inductance sensitivity using the "B1" and "B2" trimmer. The magnet passage detection cause the generation of an impulse on the output linked to the input inductance.

The main factors that can influence the capability of the instrument to detect a magnet passage are:

- **magnetic field generated by the used magnet**  
*it is recommended to use AlNiCo or Neodymium magnets and, in case of difficult detection, try magnets with different size and shape or try to change the inductance orientation.*
- **the maximum distance between inductance and magnet**  
*if you need to increment the maximum detection distance, you can adjust on the sensibility trimmer, but note that with higher sensibility the instrument become more sensible to external noise. If you are using it with PTFE coated magnets Mod. IMA, maximum recommended distance between inductance and magnet is 10-15cm with minimum amplification and 40-50cm with maximum amplification.*
- **turns quantity in the used inductance**  
*the instrument is compatible with inductance from 50Ω to 5000Ω (e.g.. Inductance of solenoid valve with AC or DC power supply).*
- **strong electromagnetic field near the inductance**  
*it is recommended to place the inductance as far as possible from noise source as transformers, electric motors or pumps, and eventually to shield the exposed sides of the inductance with a metal grid.*

## Warranty

The warranty is valid for 12 months from purchase, and expires if instrument is improperly used or not correctly installed on system.



**GESINT S.R.L.**  
Via Perosi, 5  
20010 Bareggio (MI) - ITALY  
Tel. +39-02-9014633  
Mob. +39-335-6282615  
Fax +39-02-90362295  
E-mail: info@gesintsrl.it

**GESINT.**

[WWW.GESINTSRL.IT](http://WWW.GESINTSRL.IT)