

# METER

Ultrasonic level transmitter

825B105C

## Technical Data

Housing material: PBT/PP wetted part  
 Mechanical installation: 2" GAS M on request PP flange DN50 or DN80  
 Protection degree: IP65  
 Electrical connection: Internal push actuators connectors  
 Working temperature: -30 ÷ +70°C; +80°C non-continuous  
 Pressure: from 0,5 to 1,5 bar (absolute)  
 Power supply.: 2-wire: 20÷30 Vdc / 4-wire: 24Vdc  
 Power consumption: 2-wire max 0,6W / 4-wire max 1,5W  
 Relays output: (4-wire only) -n°2 3A 230Vac  
 Digital communication: 4-wire: RS485 / HART (optional)  
 Max measure range : standard max 0.25÷5m (In case of non perfectly reflecting surfaces, the maximum distance value will be reduced)  
 Blind distance: 0.25m  
 Temperature compensation: digital from -30 to 80°C  
 Accuracy: ±0,15 % (of the measured distance) not better than ±3mm  
 Resolution: 1mm  
 Calibration: 4 buttons or by HART/RS485  
 Warm-up: 1 minutes typical  
 LCD Display : Plug-in display/keyboard 4 buttons matrix LCD



**METER**  
Ultrasonic level transmitter

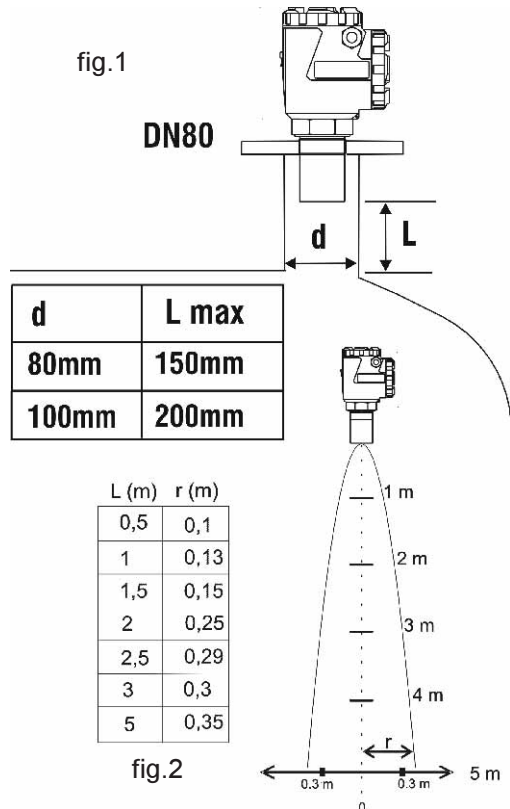

## METER Mechanical Installation

**Important!!!** close to the sensor there is a "blind zone" of 0.25m where the instrument can't measure (see fig.3). To reach a good and safe measurement, avoiding spurious echoes (not reflected by the surface), take care of the positioning of the METER sensor and check that no obstacles are interfering with the ultrasonic waves emission lobe (see fig.2).

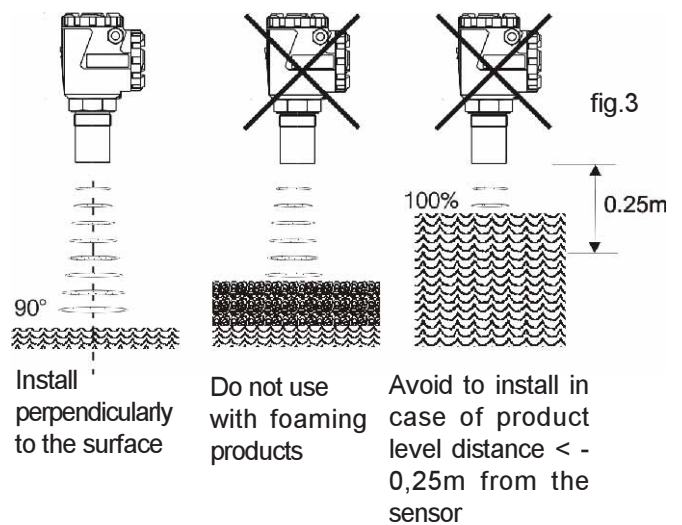

## LOW Outline dimensions

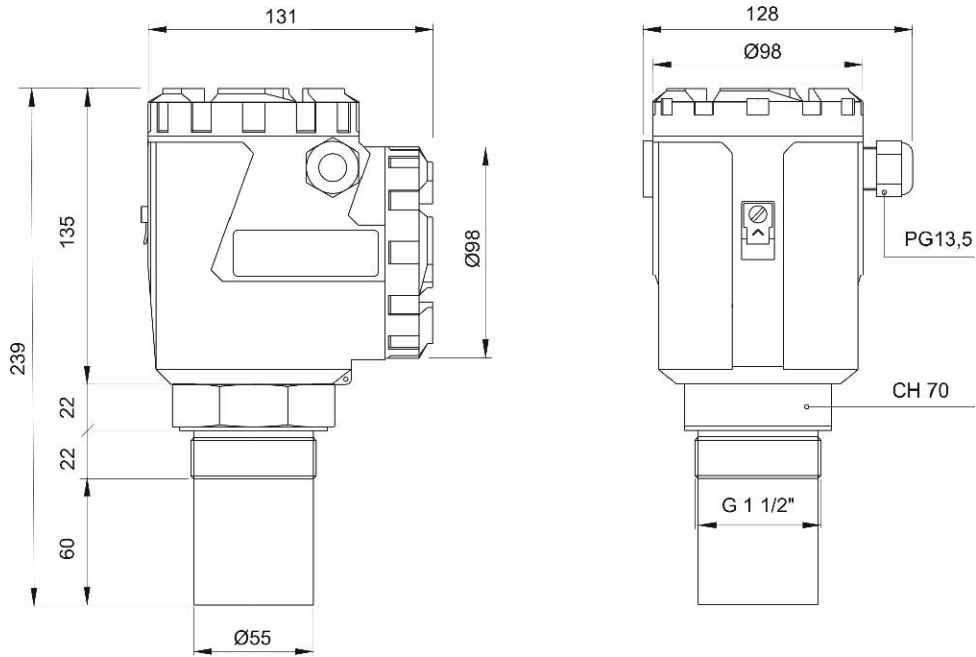

## METER Electrical connections

Unscrew and remove the cover to reach the the plug-in display/keyboard module. By pressing the drawing-spring as shown in Fig.6 -part.1 extract the module and gain the electrical (plug-in) connectors.

See Fig.7 for 2-wire versions: METER-1;METER-2 (HART); METER-3 (ATEX)

See Fig.8 for 2 relays version: METER-4

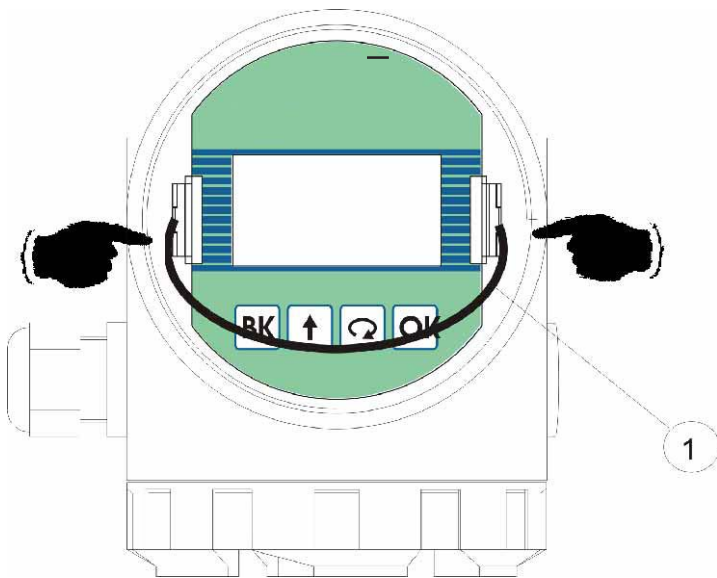

Fig.6

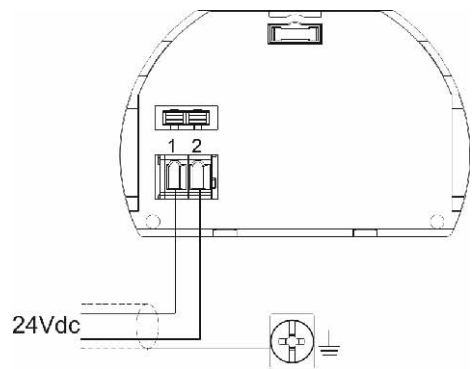

Fig.7

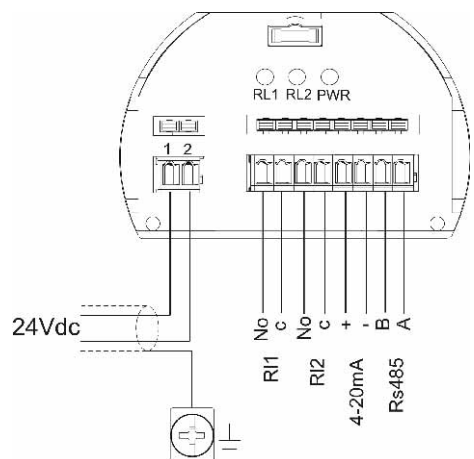

Fig.8

## Calibration

The METER configuration and calibration can be done in two different ways: by HART (Hand-Held or PC Modem) if available

- by HART Hand-Held (if available for the selected version)
- by the plug-in / keyboard module

### HART Hand Held connection (fig.9)

- 1) Hand Held
- 2) METER with HART communication protocol
- 3) 250ohm resistance

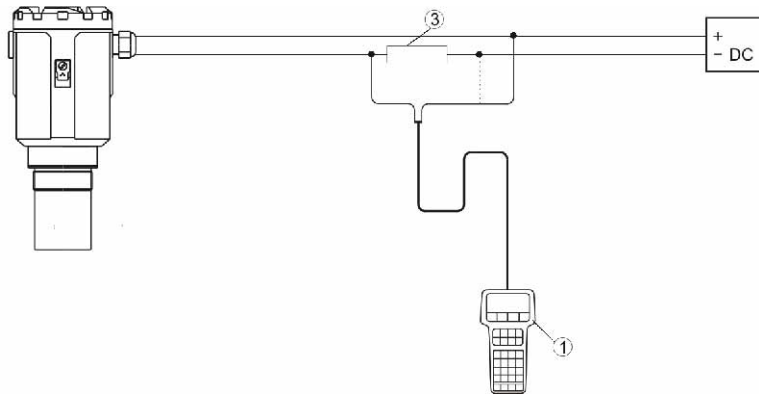

Fig.9

### PC/MODEM HART connection (Fig.10)

- 1) RS232 connector
- 2) METER with HART communication protocol
- 3) 250ohm resistance
- 4) HART MODEM

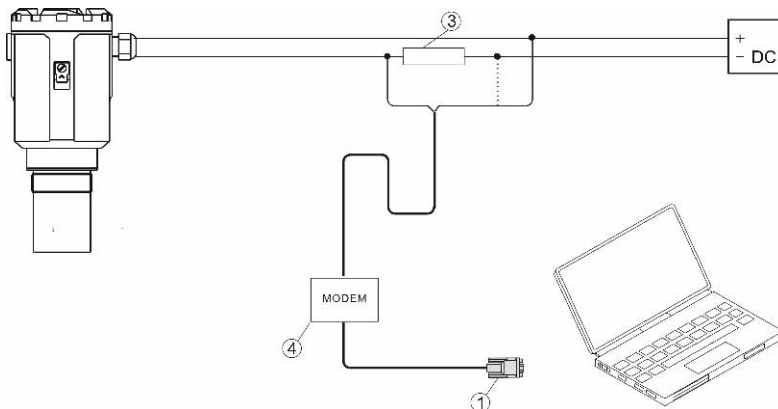

Fig.10

## Programming display

The programming display (fig.11) has a large matrix LCD. The operating manual allows an easy and fast start up through the keyboard (fig.11)

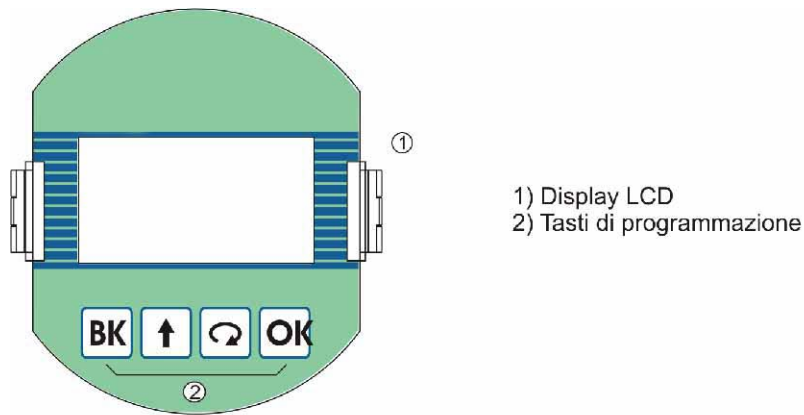







Fig.11

 Il tasto “**OK**” consente di confermare la selezione del cursore e dei valori numerici inseriti

 Il tasto “” consente di muovere dall'alto verso il basso il cursore di selezione alla cifra adiacente verso DX nei campi di inserimento numerico

 Il tasto “” consente di variare le cifre nei campi di inserimento numerico

 Il tasto “**BK**” consente di ritornare alla finestra da cui si proviene



# METER - Operating manual

The menù structure is shown on pages 17/18.

From "RUN" mode, press **OK** to enter "PROGRAM" mode. Press **BK** to quit

Press **↶** to move the cursor on the parameter you want to use and confirm with **OK**

To edit numbers, press **↑** to modify the digit shown in negative, press **↶** to edit the next digit, press **OK** to confirm and store the number. Press **BK** to quit

## Programming menù

1. SETUP – in this menù it's possible to set the basic adjustment of the sensor
2. DISPLAY – in this menù it's possible to setup the sensor display mode and adjust the B/W contrast of LCD
3. DIAGNOSTIC - in this menù it's possible to test and check the sensor, display peak values and measure status.
4. SERVICE - in this menù it's possible to set com mode, output mode, language, input password to enable parameters
5. INFO - this menù show firmware revision, serial number and manufacturer information

## SETUP (1)

From "RUN" mode press **OK** then move the cursor on "SETUP" and confirm with



Select the parameters by moving the cursor with **↶**, and confirm with **OK**



### ACTUAL LEV. 4mA :

press **OK** to associate the actual measure with 4mA output value; the following message will be displayed:  
OK TO CONFIRM press **↶** to confirm

### ACTUAL LEV. 20mA:

press **↑** to associate the actual measure with 20mA output value; the following message will be displayed:  
OK TO CONFIRM press **OK** to confirm

# METER - Operating manual

## SET DISTANCE 4mA:

press **OK** to display the value of distance associated with 4mA output; use **↑** and **↺** to modify that value. Confirm with **OK**



## SET DISTANCE 20mA:

press **OK** to display the value of distance associated with 20mA output; use **↑** and **↺** to modify that value. Confirm with **OK**



## MEDIUM:

select LIQUIDS if the sensor is measuring a liquid level, else select SOLIDS



## FILTER COEFFICIENT:

input a value from 1 to 100 (10 default) to smooth the response of the sensor: the biggest is the value, the smoothest is the response



# METER - Operating manual

## BLIND DISTANCE:

represent the "BLIND ZONE" of the sensor. Input the desired value in order to avoid measures near the surface of the sensor (if necessary). The minimum value is 250mm





## RELAY:

**in this sub-menù it's possible to setup onboard relays (only LOW-4 model).**

RL1 can be set as **threshold** relay or **pump-control** relay; RL2 can be set as **threshold** relay or **diagnostic** relay



## RL1 THRESHOLD/RL2 THRESHOLD:

select the parameter by moving the cursor with  and confirm with 

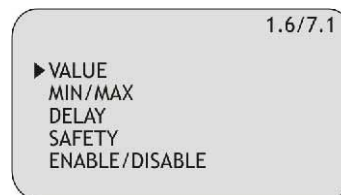

## VALUE:

it's possible to input the threshold value, **in terms of percentage of level**

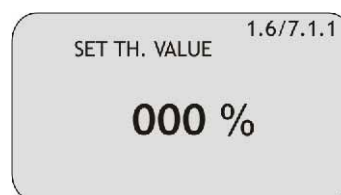

## MIN/MAX:

it's possible to select if the relay works as maximum level threshold or minimum level threshold

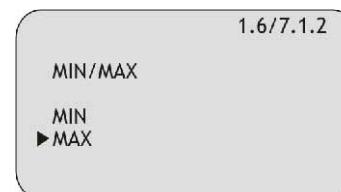

# METER - Operating manual

## DELAY:

it's possible to select the delay of activation for the selected relay, from 0 to 99 sec. (0s default)



## SAFETY:

it's possible to select if the coil of relay is normally EXCITED (YES) or normally DISEXCITED (NO)

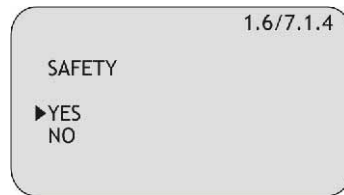

## ENABLE/DISABLE:

select ENABLE to allow the relay to work in the selected mode (Threshold/Pump or Threshold/Diagnostic)



## RL1 PUMP:

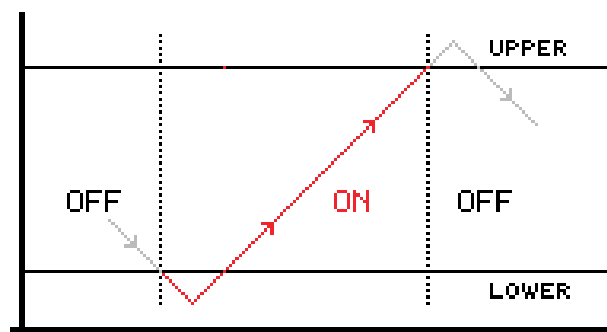

it's possible to allow **pump control** with RL1, also in **FILLING** mode or **EMPTYING** mode.

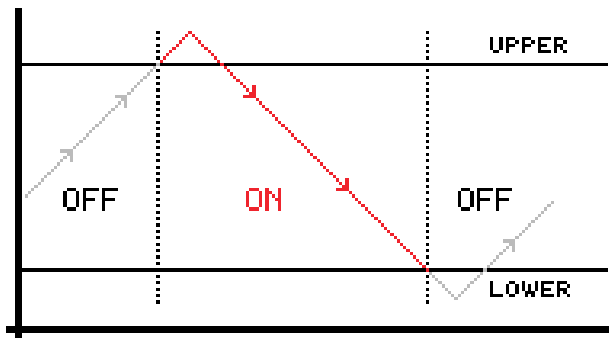

FILLING MODE



## EMPTYING MODE

Select the parameter by moving the cursor with  and confirm with 

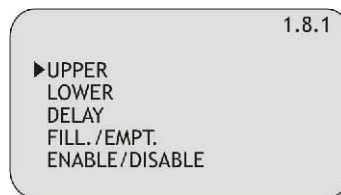

### UPPER:

it's possible to input the upper level value, to enable start emptying or stop filling.



### LOWER:

it's possible to input the lower level value, to enable stop emptying or start filling.

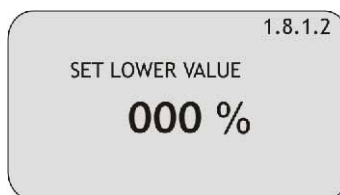

### DELAY:

it's possible to select the delay of activation for the selected relay, from 0 to 99 sec. (0s default)



## FILL./EMPT.:

it's possible to select the mode of pump control (filling or emptying)

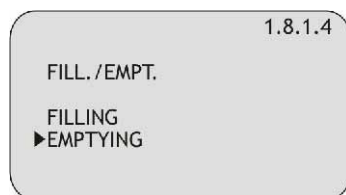

## ENABLE/DISABLE:

select ENABLE to allow the relay to work in the selected mode

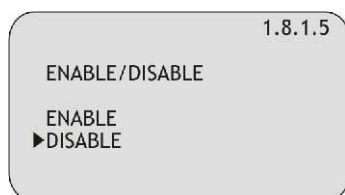

## RL2 DIAGNOSTIC:

it's possible to enable RL2 to activate its contact in case of error as:

- TEMP.: temperatutre out of range
- ECHO: no echo is detected
- GAIN: the sensor's gain exceed the value setted in Max Gain TH (3.4)
- DIST.: the measured distance exceed the 120% of the maximum distance in setup

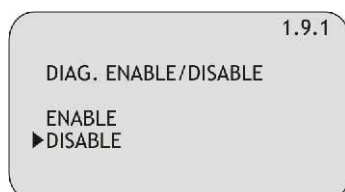

**NOTE:** when an error occurs, a "I" is flashing on the display: press  to show a message that indicate what kind of error is present

## DISPLAY (2)

From "RUN" mode press **OK**, then move the cursor on "DISPLAY" and confirm with **OK**



Select the parameters by moving the cursor with , and confirm with

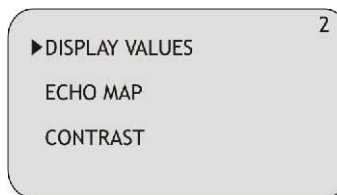

### DISPLAY VALUES:

It's possible to select if one value with big digits or two values are shown on the display in "RUN" mode



### 1 VALUE:

only one value is displayed; it's possible to choose from 5 parameters:

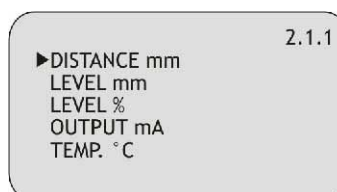

## 2 VALUES:

two values are displayed; it's possible to choose which one is the primary and which is the secondary, each with a choice of 5 parameters

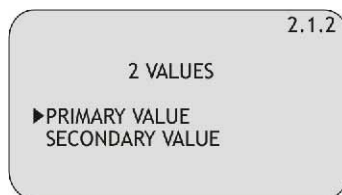

## ECHO MAP:

NOT YET AVAILABLE

## CONTRAST:

it's possible to adjust the contrast of LCD, simply increasing or decreasing the value of a parameter from 0 to 63 (16 default)



## DIAGNOSTIC (3)

From "RUN" mode press **OK**, then move the cursor on "DIAGNOSTIC" and confirm with **OK**

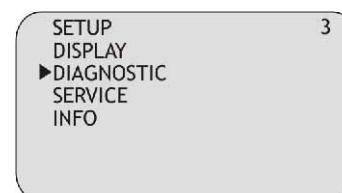

Select the parameters by moving the cursor with , and confirm with **OK**

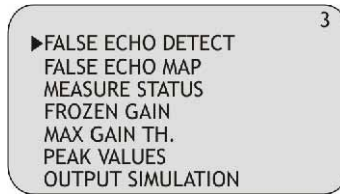

## FALSE ECHO DETECT:

It's possible to scan the empty tank in order to avoid obstacles like agitators' blades, limit switches, mechanical struts

It's necessary to input the empty distance (distance from the instrument to the bottom of the tank) and confirm with **OK**



The system will automatically scan and store all echoes separating false echoes from the real one that match the empty distance. After this, the following message is displayed: **FALSE ECHO DETECT DONE**

If something's not correct (e.g. wrong empty distance value, obstacles that hide the bottom) the following message is displayed **FALSE ECHO DETECT ERROR**

**Note: False echo detect procedure is not recommended for pipe and stand-pipe applications**

## FALSE ECHO MAP:

NOT YET AVAILABLE

## MEASURE STATUS:

it's possible to display the gain of the system, with values from 0 to 255. While displayed, the automatic gain control is not active

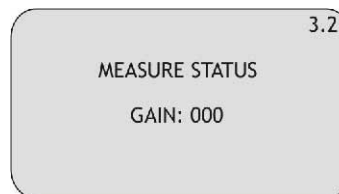

## FROZEN GAIN:

it's possible to fix a value of gain (from 1 to 255) and consequently disable the automatic gain control.

Once the value is 000 the automatic gain control restarts

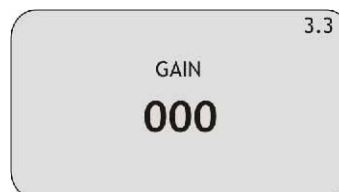

## MAX GAIN TH:

it's possible to input a value of gain that it should be not reached. If the gain is above this value, an error occurs



## PEAK VALUES:

the system store the maximum distance and the minimum distance measured since the power is turned ON. It's possible to see those values or reset the



Select DISPLAY VALUES and confirm with **OK**

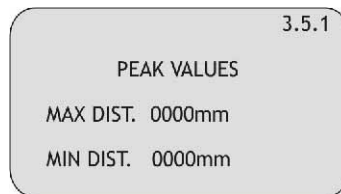

Select RESET VALUES and confirm with **OK** in order to cancel the stored values



## OUTPUT SIMULATION:

it's possible to force the analog output to a desired value, simply by using **↑** and **↺** to modify that value. Confirm with **OK**. The output returns to its normal function in only in "RUN" mode.



## SERVICE (4)

From "RUN" mode press **OK**, then move the cursor on "SERVICE" and confirm with **OK**



Select the parameters by moving the cursor with , and confirm with **OK**

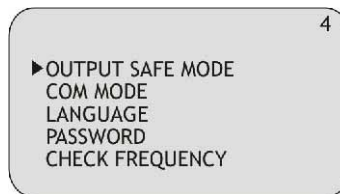

### OUTPUT SAFE MODE:

it's possible to choose a value of analog output durin condition of system's internal errors.  
Hold last value keep the output at the level corresponding at last valid measure.

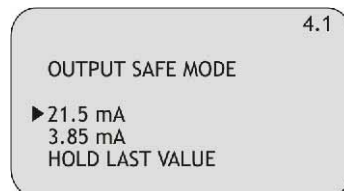

### COM MODE:

NOT YET ACTIVE

### LANGUAGE:

NOT YET ACTIVE

### PASSWORD:

NOT YET ACTICE

## CHECK FREQUENCY:

it's possible to check the computed emission frequency of the sensor.

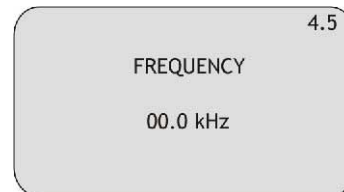
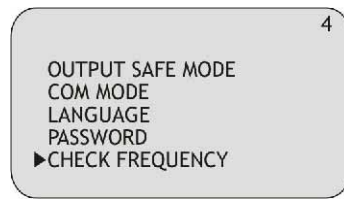

## INFO (5)

From "RUN" mode press **OK**, then move the cursor on "INFO" and confirm with **OK**

Informations about manufacturer, firmware version and serial number are displayed

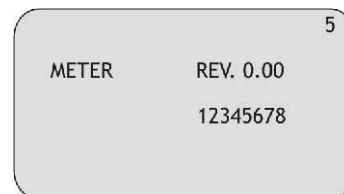

# METER Programming menu structure

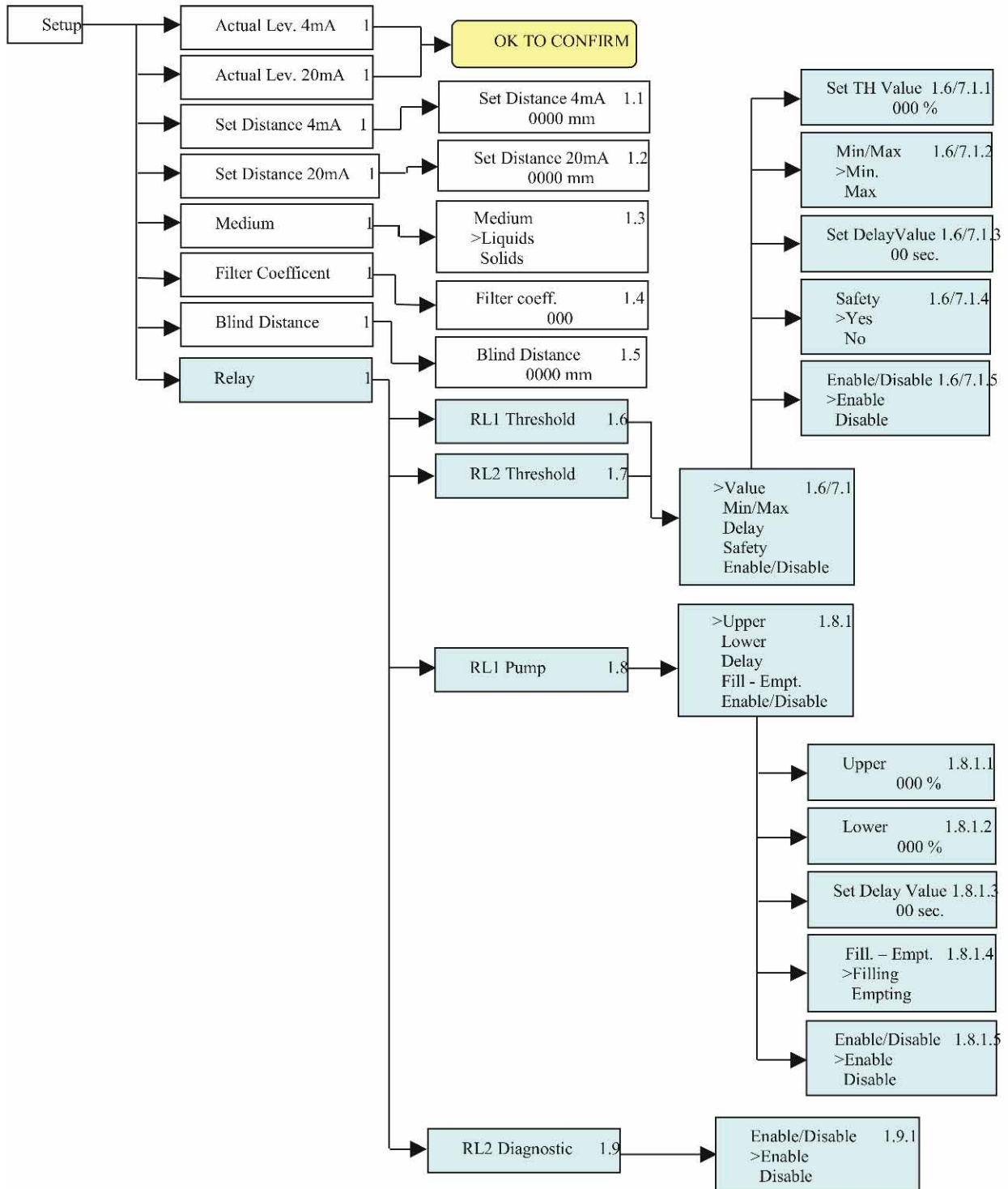

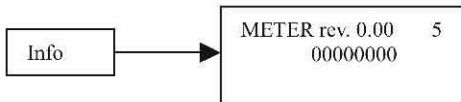
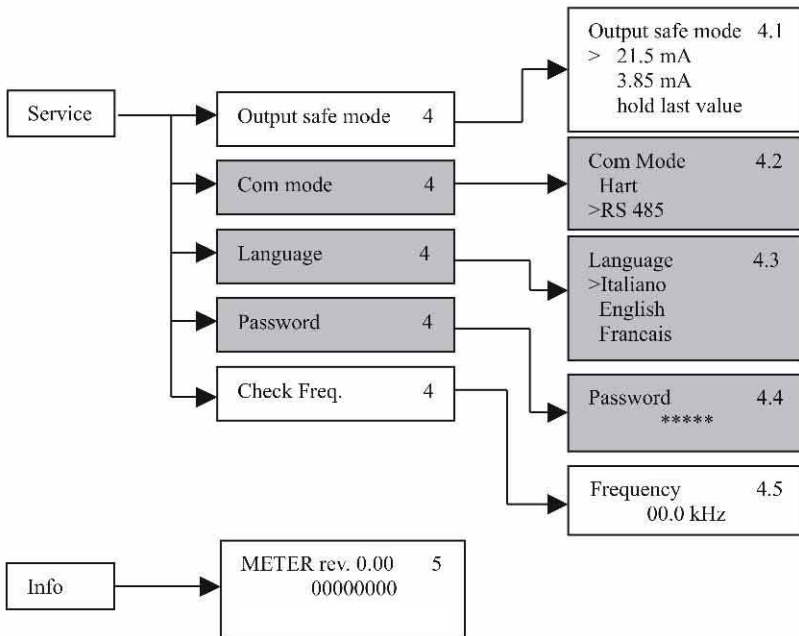
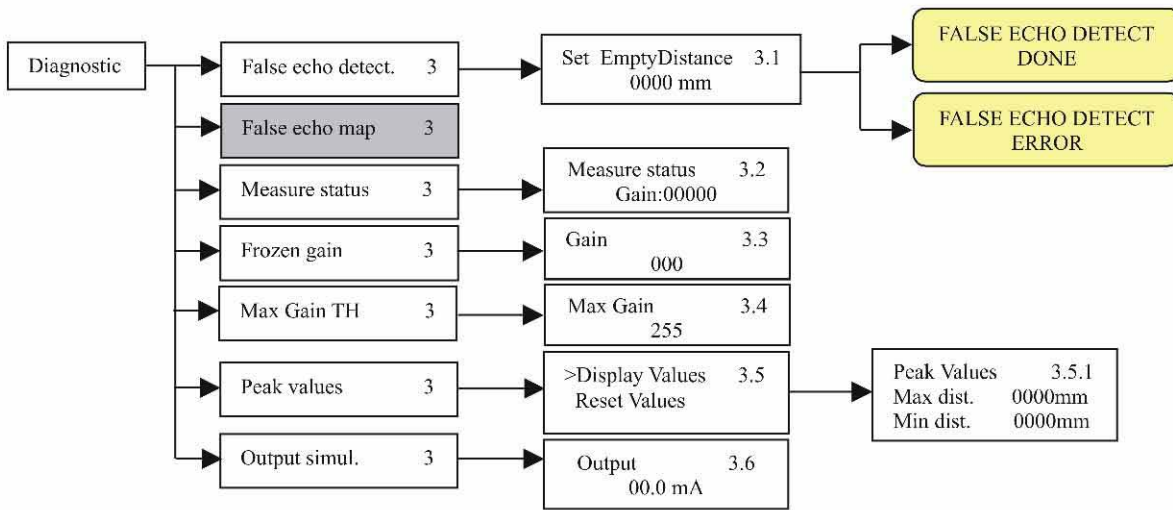
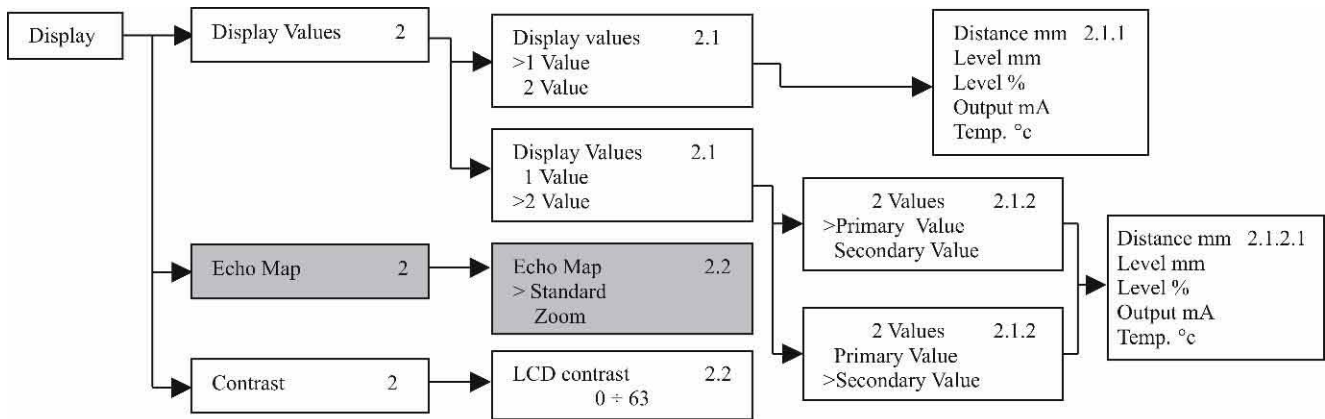

**GESINT S.R.L.**  
 Via Perosi, 5  
 20010 Bareggio (MI) - ITALY  
 Tel. 02/9014633 - 335/6282615  
 Fax 02/90362295

**GESINT.** e-mail: [info@gesintsrl.it](mailto:info@gesintsrl.it)  
**WWW.GESINTSRL.IT**