

# SWING

865B042A

Level, differential level, open channel flow, and pumps controll

## SWING

- Level measure
- Differential level measure
- Open channel flow measure
- Up to 5 pumps controllers
- Up to 2 ultrasonic level sensor connected
- The rear illuminated alphanumeric display can be showed 2 different measure
- Transparent frontal for the reading display
- Data input by 5 keys
- Easy access to the keys thanks the rapid closing door
- IP65 ABS enclosure for external installation
- Wall mounted enclosure
- Power supply: 24/115/230Vac 50Hz
- Power consumption: 15W
- N.2 RS485 serial input for the PTU or SMART ultrasonic sensor family connection
- Ultrasonic measure sensor coupled:
  - PTU05 (0,3÷5m IP68)
  - PTU10 (0,4÷8m IP68)
  - PTU15 (0,7÷12m IP68)
  - SmartCost (0,25÷5m IP65/68)
  - 521Smart (0,6÷10m IP65)
  - 522Smart (0,7÷15m IP65)
- N.2 4÷20mA analog output
- N.5 relays output (5A 250Vac)



- Level and open channel flow measurements**
- Pumps controller**
- Wall mounted**
- IP65 mechanical protection**
- Power supply: 24Vac, 115Vac, 230Vac**
- Output: 5 relays outputs**  
**Dual 4÷20mA analogs outputs**

### **Presentation**

The not intrusive system application is by now privileged in the level measure sector. For this reason has been developed the ultrasonic level sensor line, PTU and SMART family, together with a data elaboration unit like the SWING. The SWING unit has a multiplicity of programmable functions and of base parameters already inserted for permit a simplicity of start. All the ultrasonic level sensors are coupling to the SWING, in particular way the PTU family.

### **Operation**

The ultrasonic level sensor, connected to the SWING unit, send a sonorous impulse toward the product surface of which needs to measure the level. The sonorous impulse comes reflex toward the sensor, that interceptes the return. The sensor inside system now is able to elaborate the sonorous impulse flight time, and it can extrapolate the product surface distance from the sensor, then sending this last datum to the SWING unit. The SWING unit now is able to elaborate all the internal measura parameters, and it's going to show the results on its display.



GESINT.

# SWING

## TECHNICAL DATA

Enclosure: **IP65, for external installation, wall mounted**  
 Enclosure material: **ABS color RAL 7035**  
 Keyboard: **5 keys**  
 Display: **back lighted graphic LCD 128x64**  
 Electrical connections: **screw-connectors, separate access**  
 Power supply (depends to the model): **24/115/230Vca;±10%**  
 Power consumption: **max 15W**  
 Ultrasonic sensor: **IP68 PTU family, IP65 Smart family**  
 Technology: **digital, using Flash microprocessor**  
 Custom parameters memory: **EEPROM**  
 Internal supply for transmitter: **24Vdc-200mA max**  
 Relays output (depends to the model): **3 or 5**  
 Contact rating: **5A 250V (resistive)**  
 Analogue output: **n.2 4÷20mA galvanic separation**  
 Working temperature: **-20°C ÷ +60°C**  
 CE conformity: **93/68 CEE**

## Overall dimensions(in mm.)

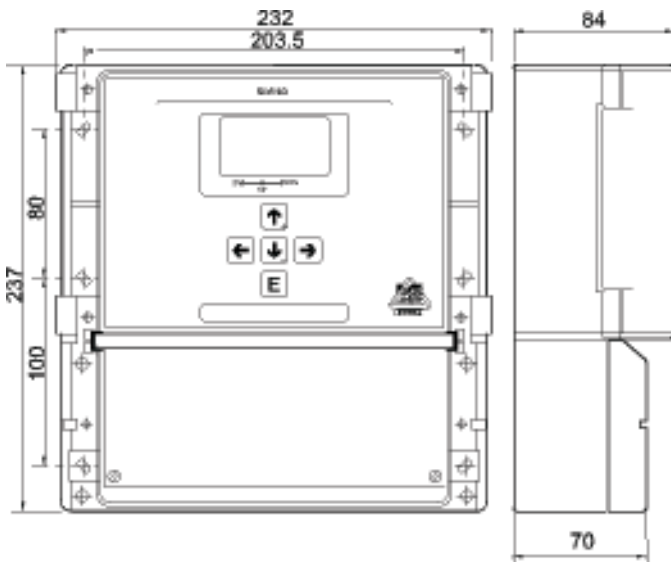

## Fixing-Bracket with ground fixing plate

Vessel/channel lateral telescopic fixing-bracket with ground fixing plate and swing sun protector plate. Open channel flow measurement applications suitable accessories.



## Electrical connections

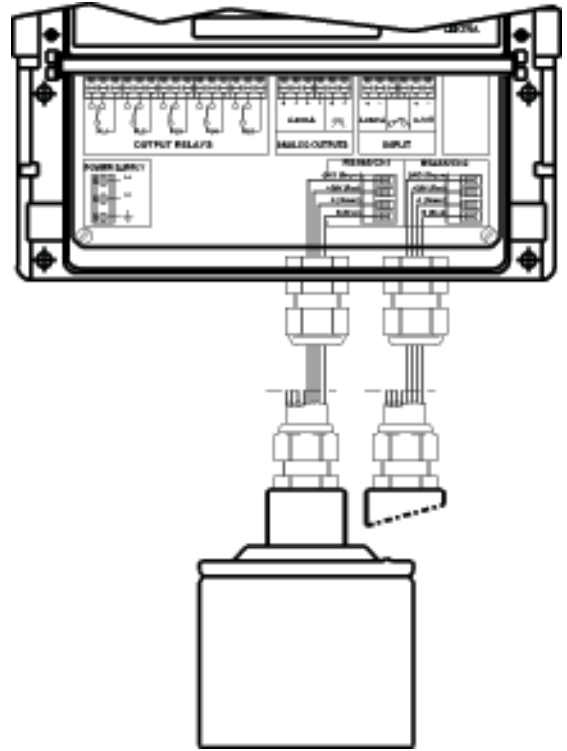

Dual channel PTU electrical connections

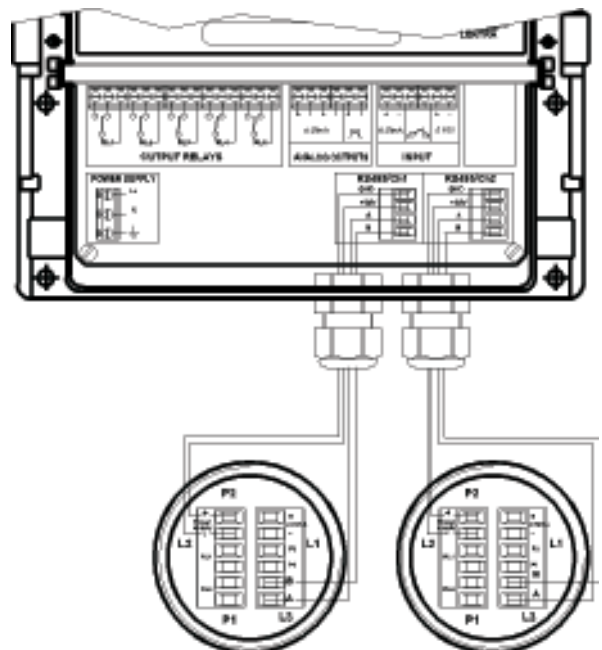

Dual channel SMARTCOST electrical connections

## Applications

Swing unit is indicated for open channel flow measurement with PTU ultrasonics sensor.

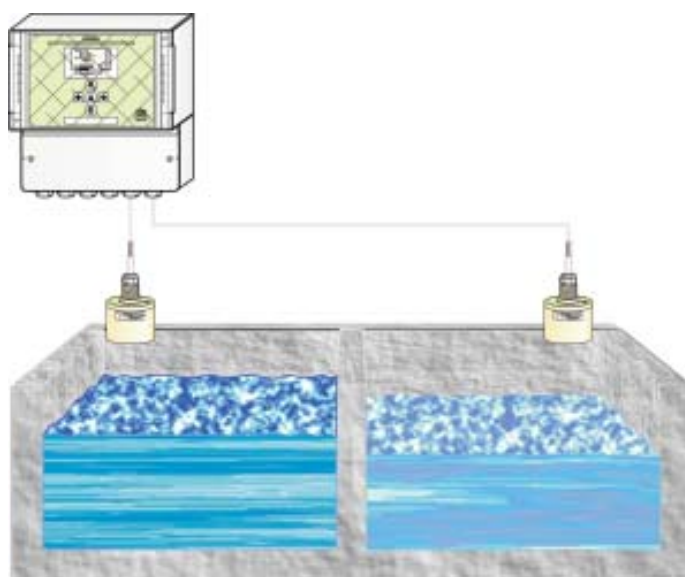
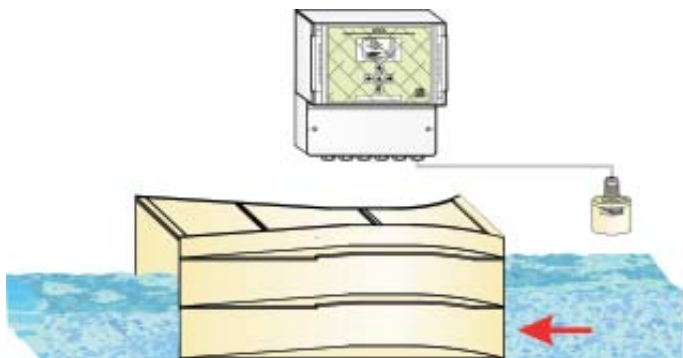

A series of PP Venturi open flumes are available.

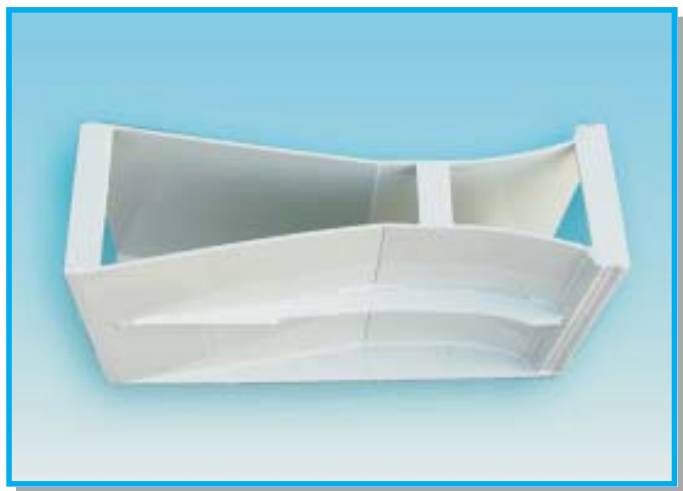

The SWING unit can run two different applications, like a pumps control and a level measurement, because the two input channels are separately tuned.

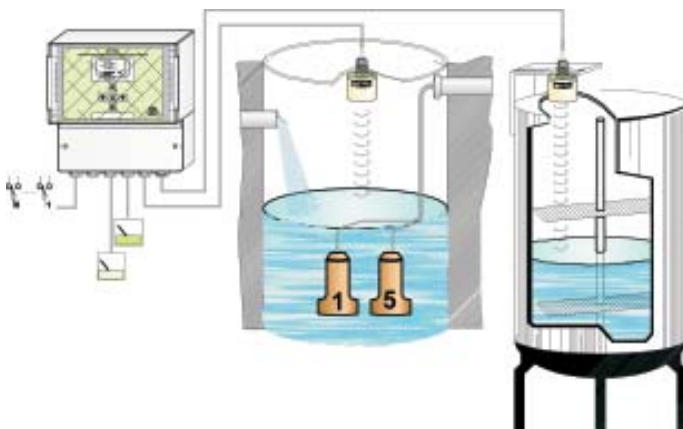

It's possible to run a differential level measurement when SWING unit is connected with two level measurement.

## Programming structure:

Swing has three different access levels:

- **MENU**
- **GROUPS**
- **PARAMETERS**

Each **MENU** include different **GROUPS**, each **GROUP** has a few **PARAMETERS**.

5 keys allow the control and the configuration/programming of all the SWING operative functions.

4 keys can move the cursor into the parameters map. Jump from one to another **MENU**, or nested from **MENU** to **GROUP** and to the relevant parameters. [ **E** ] key, is used for data confirmation.

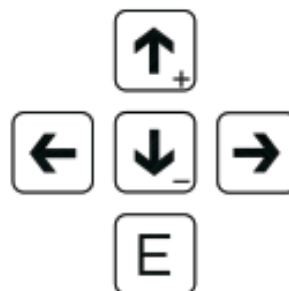
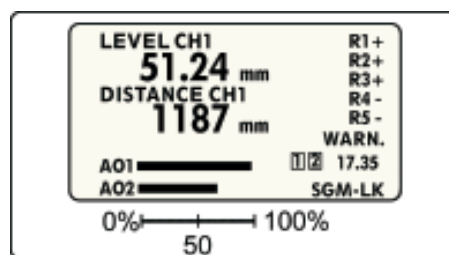

## Example; changing of a parameter in the MENU"LEVEL"

An example of a parameter modification is showed in this page.

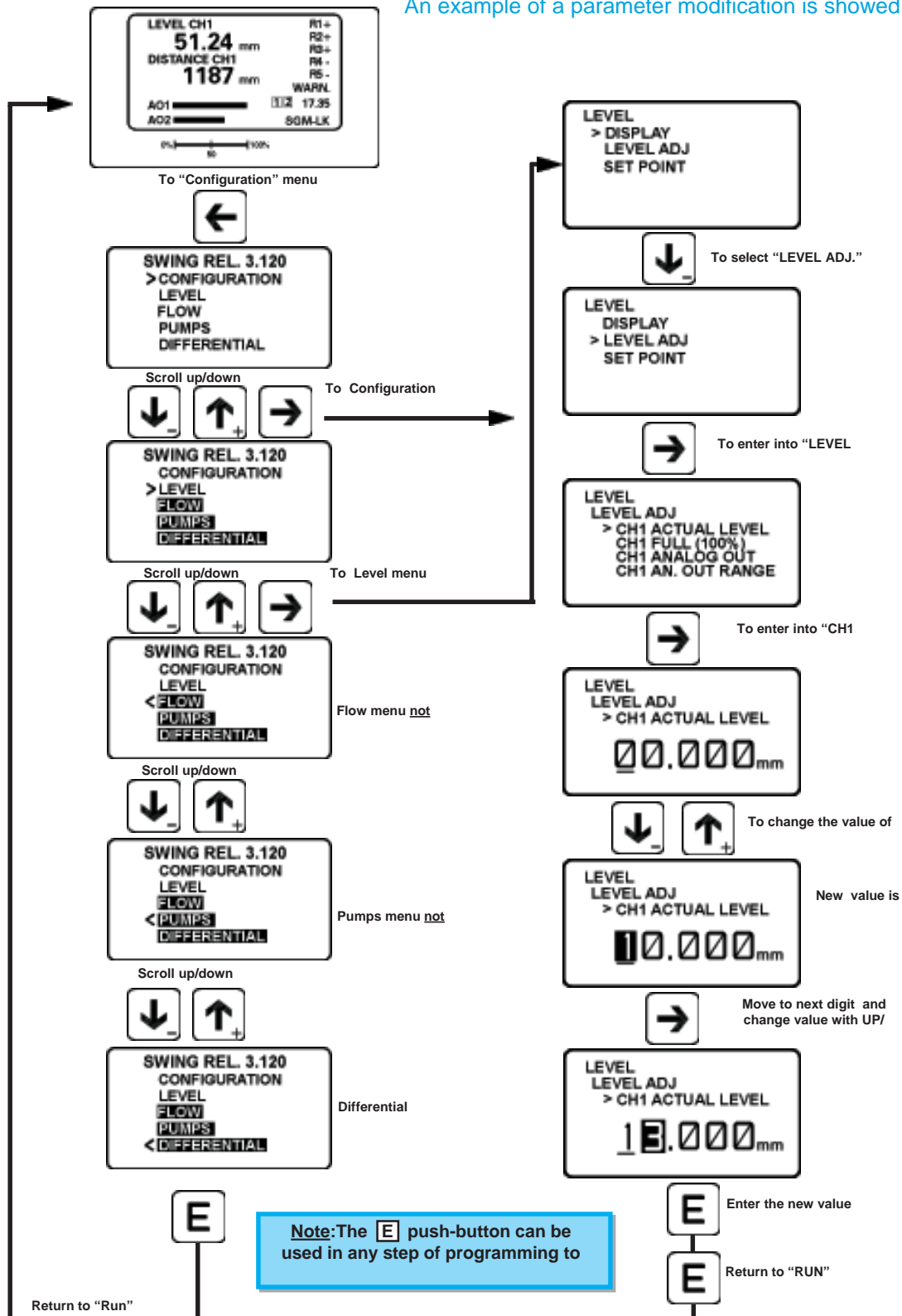

All the modification operations are runned by the on board keys.

The total unit configuration can be completed in a short time because a lot of operative functions are already included.



GESINT S.r.l.  
Via Perosi, 5  
20010 Bareggio (MI)  
Tel. 02/9014633 - 335/6282615  
Fax. 02/90362295  
e-mail: [info@gesintsrl.it](mailto:info@gesintsrl.it)  
[WWW.GESINTSRL.IT](http://WWW.GESINTSRL.IT)