



The FLS FlowX3 F3110M and F3111M electromagnetic flowmeters are suitable for use in pipelines of both metal and thermoplastic. They can measure liquids where suspended solids are present or abrasive liquids as long as they are conductive and homogeneous. A specially designed family of fittings ensures a quick installation into all pipes from DN50 (2"). The 3111M version can be assembled in pressurized pipes using a proper weld-on adapter and isolation valve or a proper clamp saddle.

Main Features

- High mechanical resistance.
- Suitable for liquids at high temperature.
- High operating pressures.
- No moving parts, no wear, maintenance free.
- Pipe size from DN 50 (2").
- Electronic replaceable without removing the instrument.
- Low power consumption.
- Hot-Tap installation.

Applications

- Waste water treatment.
- Raw water intake.
- Textile finishing.
- Water distribution.
- Processing and manufacturing industry.

Technical Features

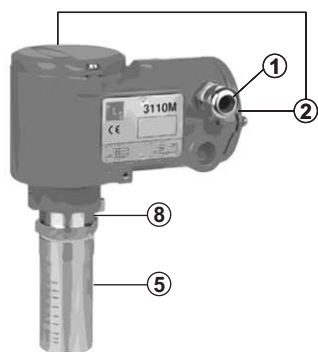

Sensor for installation on metal pipes

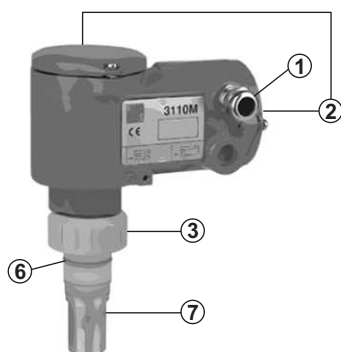

Sensor for installation on plastic pipes

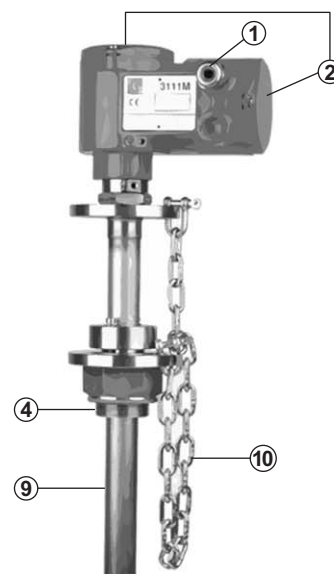

Sensor for big sizes or Hot-Tap installation

- 1) PG13.5 Cable Gland
- 2) Removable caps for wiring and setting
- 3) CPVC cap for installation into plastic fittings
- 4) 1 1/2" GAS thread for installation into metal fittings
- 5) Stainless Steel joint for sensor installation
- 6) O-Ring seals available in FPM
- 7) PVDF and Stainless Steel sensor body
- 8) Stainless Steel sensor body
- 9) Stainless Steel adjustable sensor body
- 10) Security chain for Hot-Tap installation

Operating principle

If an electrical conductor is caused to move in a magnetic field, such movement induces a voltage in the conductor (Faraday's law). The two magnetic coils in the body of the instrument generate a magnetic field perpendicular to the flow direction. The magnetic field **B** and the velocity **v** induce a voltage **U** between the central electrode and the stainless steel body.

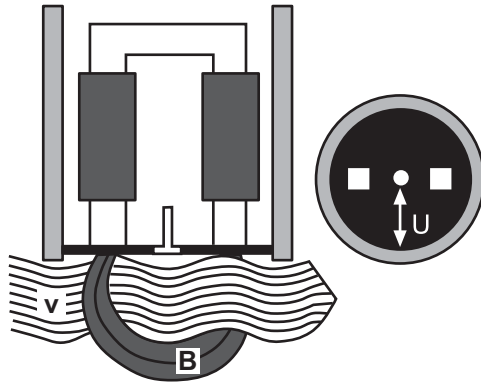

The voltage **U** is directly proportional to the flow velocity **v**:

$$U = K \times B \times v \times D$$

K = instrument constant

B = strength of magnetic field

v = local flow velocity

D = distance between the two electrodes.

The voltage is converted into a flow proportional 4-20 mA output signal.

Engineering Data

- The flow sensor uses an electromagnetic technology with no moving parts applied to insertion-style mounting.
- The sensor is available in three different versions for installation on metal pipes, plastic pipes or for Hot-Tap installation.
- The sensor provides a passive 4-20 mA output with 500 Ω maximum load.

- The flow operating range of the sensor is from 0.15 to 8 m/s (0.5 to 25 ft/s).
- The minimum fluid conductivity must be of 20 μ S.
- The sensor provides a field replacement of the electronic without removing the instrument from the pipe.

Dimensions F3110M.1 Stainless Steel version for installation on metal pipes

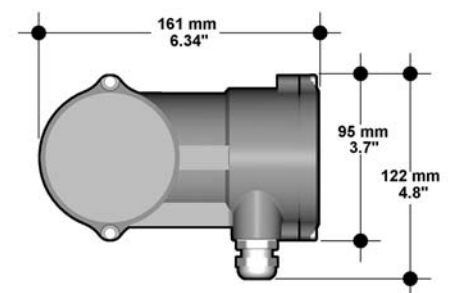
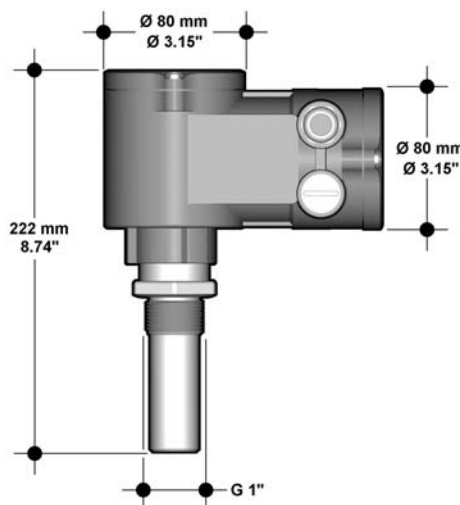

F3110M/F3111M

Dimensions F3110M.2 and F3110M.3 PVDF version for installation on plastic pipes

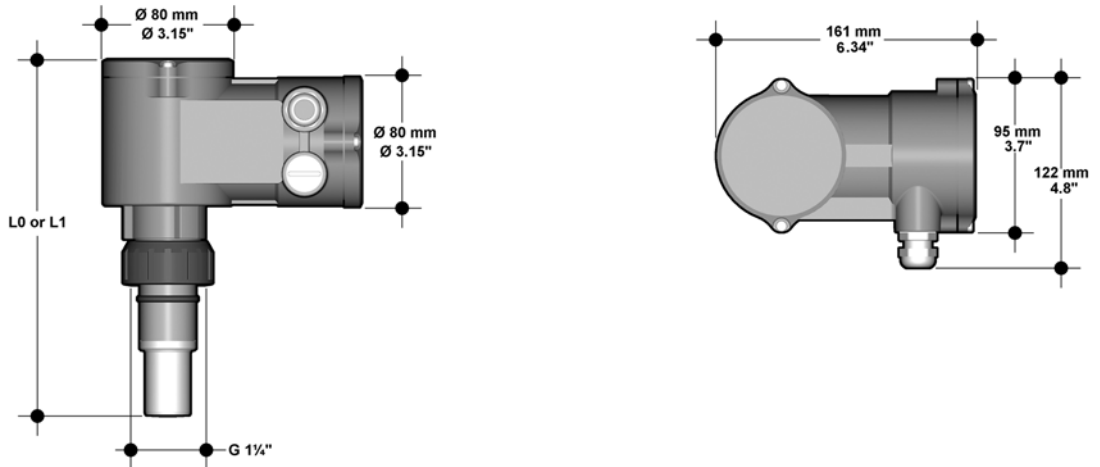

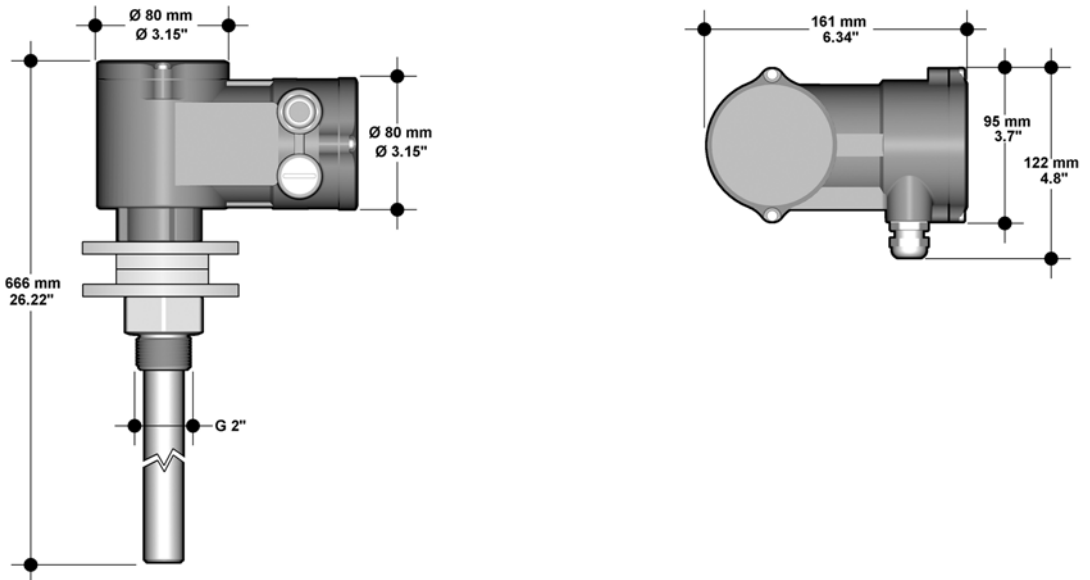

F3111M.X Hot-Tap version for installation in pressurized pipes



Installation Fittings

Please refer to Installation Fittings section for more details and a complete listing of items.

	Type	Description
	CPVC Clamp Saddles	Size: D63 to D225 (2" to 8") Insert materials: CPVC, PVDF
	316L SS Weld-on Adapter	Size: D63 to D400 (2 to 16") Directly included into F3110M.1 version
	316L SS Big Size Weld-on Adapter	Size: D400 (16") or greater For F3111M installation

Installation Guidelines

- Different pipe configurations and obstacles in the flow line such as valves, elbows, pipe bends and strainers create variations on the flow profile.
- The six most common installation configurations are shown to help in selecting the best location in the pipeline for paddlewheel flow sensor.
- For more information, please refer to EN ISO 5167-1.
- Always maximize distance between flow sensors and pumps.

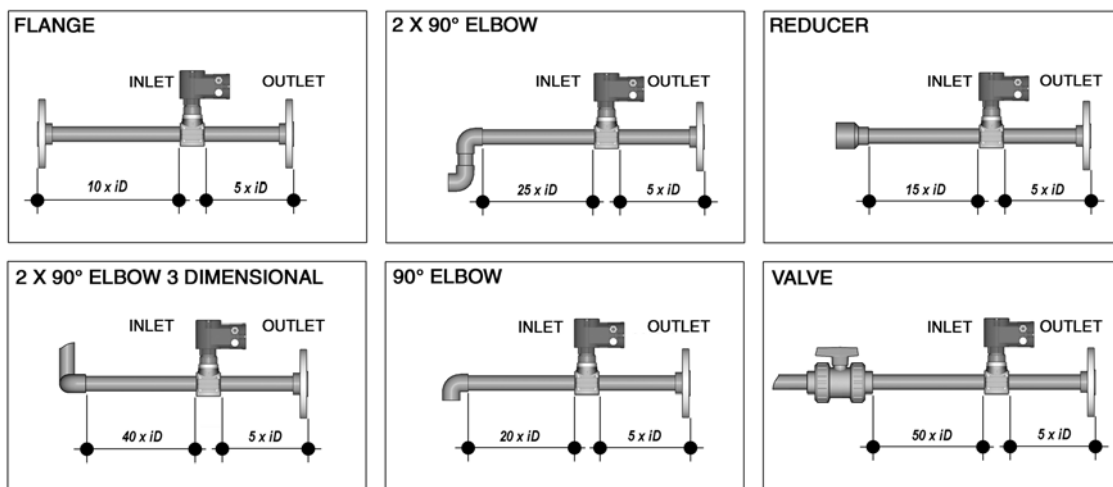

Mounting Positions

- Make sure the pipeline is always full.
- Horizontal pipe runs: Sensor can be installed in any orientation. If sediments or air bubbles are present avoid top or bottom orientation.
 - Vertical pipe runs: Install sensor in any orientation. Upward flow is preferred to ensure full pipe.

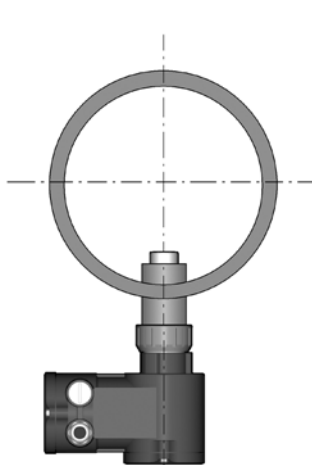

Fig. 1

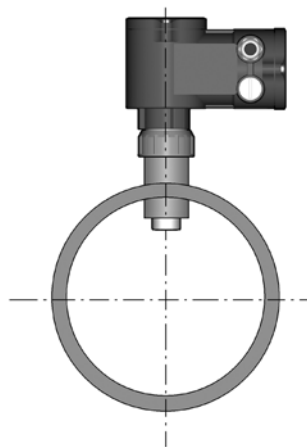

Fig. 2

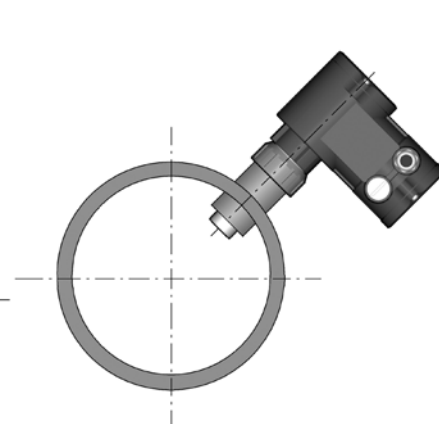
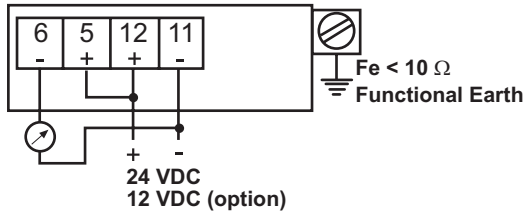
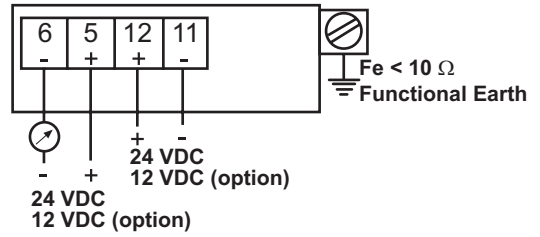

Fig. 3

Wiring Common Power Supply (3-wire)



Separate Power Supply (4-wire)



Technical Data

General

- Supply voltage: 24 VDC (option 12 VDC) + 20% regulated.
- Supply current: max 50mA @ 24 VDC @ 20°C (68°F).
- Output signal: 4-20mA passive current, adjustable.
- Max Load Impedance: 500 Ω @ 24VDC, 200 Ω @ 12VDC.
- Protective earth: < 10 Ω.
- Flow Rate Range: 0.15 to 8 m/s (0.5 to 25 ft./s).
- Full Scale Range: 1, 2, 3, 4, 5, 6, 7, 8 m/s (3.3, 6.6, 9.9, 13.1, 16.4, 19.6, 22.9, 26.2 ft/s).

- Time constant: 5 seconds, fixed.

Linearity:

- ± 2% of measured value with $v > 1$ m/s (3.3 ft/s).
- ± 3 cm/s + 2% of measured value with $v < 1$ m/s (3.3 ft/s).

- Repeatability: ± 1 % of measured value.
- Enclosure: IP65 aluminum epoxy coated.
- Cable gland: nickel-plated brass

Standards & Approvals

- Manufactured under ISO 9002.
- CE.

Specific for F3110M.1

- Pipe Size Range: DN50 to DN400 (2" to 16"). Please refer to Installation Fittings section for more details.
- Fluid conditions:
 - Min Electrical Conductivity: 20 μS
 - Temperature: -25 to 150°C (-13 to 302°F)
 - Max Pressure: 25bar (360 psi).
- Ambient temperature: -25 to 60°C (-13 to 140°F).
- Wetted Materials:
 - Sensor Body: CrNi – SS AISI 316L and ceramic
 - Electrode: Platinum
 - Fitting gasket: Klingerit without asbestos
 - Installation weld-on adapter: SS AISI 316L.

Specific for F3111M.X

- Pipe Size Range: from DN80 (3") standard.
- Fluid conditions:
 - Min Electrical Conductivity: 20 μS
 - Temperature: -25 to 150°C (-13 to 302°F)
 - Max Pressure: 25bar (360 psi).
- Ambient temperature: -25 to 60°C (-13 to 140°F).
- Wetted Materials:
 - Sensor Body: CrNi – SS AISI 316L and ceramic
 - Electrode: Platinum
 - Fitting gasket: Klingerit without asbestos
 - Installation weld-on adapter: SS AISI 316L.

Specific for F3110M.2 and F3110M.3

- Pipe Size Range: DN50 to DN200 (2" to 8"). Please refer to Installation Fittings section for more details.
- Fluid conditions:
 - Min Electrical Conductivity: 20 μS
 - Temperature: -25 to 100°C (-13 to 212°F)
 - Max Pressure: 10bar (144 psi).
- Ambient temperature: -25 to 60°C (-13 to 140°F).
- Wetted Materials:
 - Sensor Body: CrNi – SS AISI 316L, PVDF and ceramic
 - Electrode: Platinum
 - Fitting gasket: FPM.

Ordering Data

FlowX3 F3110M.X

Part No.	Name	Adapter
F3110M.1	Electromagnetic Flowmeter with SS body for installation on metal pipes	SS Weld-on adapter included
F3110M.2	Electromagnetic Flowmeter with PVDF body for installation on plastic pipes D63 to D140 (2" to 5")	CPVC Clamp Saddle NOT included
F3110M.3	Electromagnetic Flowmeter with PVDF body for installation on plastic pipes D160 to D225 (6" to 8")	CPVC Clamp Saddle NOT included

FlowX3 F3111M.X

Part No.	Name	Adapter
F3111M.1	Long version Electromagnetic Flowmeter for installation on pipe sizes from DN400 (16")	SS Weld-on adapter included
F3111M.2	Electromagnetic Flowmeter for Hot-Tap installation	SS Weld-on adapter and isolation valve included

Spare Parts

Part No.	Name	Description
F0M.SP1	Replacement electronic module	Replacement module for F3110M.X versions
F0M.SP2	SS Weld-on Adapter	SS Weld-on Adapter for F3110M.1 installation on metal pipes
F0M.SP3	O-Rings	FPM Sensor body O-rings for F3110M.2 and F3110M.3
F0M.SP4	Gasket	Klingerit Gasket between F3110M.1 and weld-on adapter
F1M.SP1	SS Big Size Weld-on Adapter	SS Weld-on Adapter for F3111M.X installation on big metal pipes
F1M.SP2	Isolation Valve	2" Brass Ball Valve



GESINT S.R.L.
 Via Perosi, 5
 20010 Bareggio (MI) - ITALY
 Tel. 02/9014633 - 335/6282615
 Fax 02/90362295
 e-mail: info@gesintsrl.it
WWW.GESINTSRL.IT